

MICROBEAST PLUS FLYBARLESS SYSTEM INSTRUCTION MANUAL

使用說明書

HEGBP301T

ALIGN



For Quickstart Guide V4.2
主程式V4.2 快速導覽版本專用



MICROBEAST PLUS
6-AXIS MEMS SENSOR SYSTEM FOR RC-MODELS

QUICKSTART GUIDE V4.2

Thank you for buying ALIGN Products. Please read this manual carefully before assembling. We recommend that you keep this manual for future reference regarding tuning and maintenance.

承蒙閣下選用亞拓系列產品，謹表謝意。進入遙控世界之前必須告訴您許多相關的知識與注意事項，以確保您能夠在使用的過程中較得心應手。在開始操作之前，請務必詳閱本說明書，相信一定能夠給您帶來相當大的幫助，也請您妥善保管這本說明書，以作為日後參考。

Compatible with helicopter of all sizes from T-REX 250 to T-REX 800 MICROBEAST PLUS Flybarless System. Here we use T-REX 700L DOMINATOR as an example .

MICROBEAST PLUS 無平衡翼系統電子設備相容小型直昇機至大型直昇機T-REX 250~T-REX800。
在此我們以T-REX 700L DOMINATOR作為操作範例。

IMPORTANT NOTES	1	Position.....	27
SAFETY NOTES	2	Governor Menu Point C - Full Throttle Position.....	27
MICROBEAST PLUS SAFETY NOTES	5	Governor Menu Point D - Transmitter Setup.....	27
QUICKSTART GUIDE V4.2	8	Governor Menu Point E - Signal Divider.....	29
1 . HARDWARE INSTALLATION	9	Governor Menu Points F/ G/ H - Main Gear Ratio.....	29
2 . CONNECTING THE RECEIVER	10	8 . FLYING AND OPTIMIZATION	30
3 . MICROBEAST PLUS HD	12	9 . PARAMETER MENU	32
4 . PREPARING YOUR TRANSMITTER	13	Menu Point A - Swashplate Quick Trim (menu Led A Flashing).....	32
5 . RECEIVER SETUP	14	Menu Points B To K.....	32
6 . SETUP MENU	16	10 . ATTITUDECONTROL (OPTIONAL)	33
Setup Menu Point A - Device Orientation (menu Led A Solid Lit Up).....	17	Parameter Menu Point L - Attitudecontrol Mode.....	33
Setup Menu Points B, C And D.....	18	Parameter Menu Point M - Attitudecontrol Pitch.....	33
Setup Menu Point E - Rudder Servo Limit.....	19	Transmitter Programming.....	33
Setup Menu Point F - Tail Gyro Direction.....	20	Functional Test Of Attitudecontrol.....	35
Setup Menu Point G - Swashplate Servo Trim.....	20	11 . MENU OVERVIEW	36
Setup Menu Point H - Swashplate Mixing Type.....	22		
Setup Menu Point I - Swashplate Servo Directions.....	22		
Setup Menu Point J - Swashplate Servo Throw.....	23		
Setup Menu Point K - Collective Pitch.....	23		
Setup Menu Point L - Swashplate Servo Limit.....	24		
setup Menu Point K - Collective Pitch.....	24		
Setup Menu Point N - Internal Rpm Governor.....	25		
7 . GOVERNOR SETUP MENU	26		
Governor Menu Point A - Test Mode (menu Led A Flashing Slowly).....	26		
Governor Menu Point B - Motor Off/idle			

重要聲明.....	1	MENU LED 燈第 A 點-十字盤快速微調 (= 選單第 A 點閃爍).....	32
安全注意事項.....	2	選單第 B-K 點.....	32
MICROBEAST PLUS 安全注意事項.....	5	10 . 姿態模式(另購).....	33
V4.2 快速導覽.....	8	參數選單第 L 點-姿態模式.....	33
1 . 硬體安裝方法.....	9	參數選單第 M 點-姿態模式螺距.....	33
2 . 接收器連接.....	10	遙控器編程.....	33
3 . MICROBEAST PLUS HD.....	12	姿態模式功能測試.....	35
4 . 準備遙控器.....	13	11 . 選單總覽.....	36
5 . 接收器設定.....	14		
6 . 設定選單.....	16		
設定選單第 A 點-放置方位(設定選單 LED 燈第 A 點恆亮).....	17		
設定選單第 B、C、D 點.....	18		
設定選單第 E 點-尾舵伺服器極限.....	19		
設定選單第 F 點-尾舵螺儀方向.....	20		
設定選單第 G 點-十字盤伺服器微調.....	20		
設定選單第 H 點-十字盤混控類型.....	22		
設定選單第 I 點-十字盤伺服器方向.....	22		
設定選單第 J 點-十字盤伺服器行程量.....	23		
設定選單第 K 點-集體螺距.....	23		
設定選單第 L 點-十字盤伺服器極限.....	24		
設定選單第 M 點-集體螺距.....	24		
設定選單第 N 點-內建 RPM 定速模式.....	25		
7 . 定速模式設定選單.....	26		
定速模式設定選單第 A 點-測試模式(Menu LED 燈第 A 點慢速閃爍).....	26		
定速模式選單第 B 點-馬達開啓/關閉位置.....	27		
定速模式選單第 C 點-油門最大行程量.....	27		
定速模式選單第 D 點-遙控器設定.....	27		
定速模式選單第 E 點-轉速訊號分配表.....	29		
定速模式選單第 F / G / H 點之主齒輪比.....	29		
8 . 飛行及優化飛行.....	30		
9 . 參數選單.....	32		

IMPORTANT NOTES

重要聲明

ALIGN

Radio Control (R/C) multicopters are not toys. R/C multicopters utilize various high-tech components to achieve superior performance. Improper use of this product can result in serious injury or even death. Please read this manual carefully before operating, and make sure to be conscious of your own personal safety and the safety of others nearby when operating all ALIGN products. Manufacturer and seller assume no liability for the operation or the use of this product. This product is intended for use only by adults with experience flying remote control aircraft at legal flying fields. After the sale of this product we cannot be held liable over its operation or usage.

We recommend that you seek the assistance of an experienced pilot before attempting to fly our products for the first time. A local expert is the best way to properly assemble, setup, and fly your model for the first time. This product requires a certain degree of skill to operate, and is an expendable item. Any damage or dissatisfaction as a result of accidents or modifications are not covered by any warranty and cannot be returned for repair or replacement. Please contact our distributors for free technical consultation and parts at discounted rates when you experience problems during operation or maintenance. As Align Corporation Limited has no control over the use, setup, assembly, modification or misuse, no liability shall be assumed nor accepted for any resulting damage or injury. By the act of use, setup or assembly, the user accepts all resulting liability.

In addition, R/C multicopters and its components are precision electronics susceptible to interferences from external forces such as magnetic field and radio signal. Should the multicopter or any onboard photographic equipment suffers loss or crash damage as result of external magnetic or radio interferences, Align cannot be held liable as the cause is beyond our control.

As the user of this product, you are solely responsible for operating in a manner that does not endanger yourself and others or result in damage to the property of others.



遙控飛行機包括遙控直昇機與多軸飛行機（以下簡稱遙控飛行機）並非玩具，它是結合了許多高科技產品所設計出來的休閒用品，所以商品的使用不當或不熟悉都可能造成嚴重傷害甚至死亡，使用之前請務必詳讀本說明書，勿輕忽並注意自身安全。注意！任何遙控飛行機的使用，製造商和經銷商是無法對使用者於零件使用的損耗異常或組裝不當所發生之意外負任何責任，本產品是提供給有操作過遙控飛行機經驗的成人或有相當技術的人員在旁指導，並於當地合法遙控飛行場飛行，以確保安全無虞下操作使用。產品售出後本公司將不負任何操作和使用控制上的任何性能與安全責任。

遙控飛行機屬於需高操作技術且為消耗性之商品，如經拆裝使用後，會造成不等情況零件損耗，任何使用情況所造成商品不良或不滿意，將無法於保固條件內更換新品或退貨，如遇有使用操作維修問題，本公司全省分公司或代理商將提供技術指導、特價零件供應服務。對使用者的不當使用、設定、組裝、修改、或操作不良所造成的破損或傷害，本公司無法控制及負責。且遙控飛行機與配件之精密電子產品，易受外力、磁場、訊號干擾，在使用過程中如外力、磁場、訊號干擾，導致飛行機本身、及其搭載之攝影設備、器材之損壞或滅失，本公司亦無法控制及負責。

做為本產品的使用者，您，是唯一對於您自己操作的環境及行為負全部的責任之人。

WARNING LABEL LEGEND

標誌代表涵義

 FORBIDDEN 禁止	Do not attempt under any circumstances. 在任何禁止的環境下，請勿嘗試操作。
 WARNING 警告	Mishandling due to failure to follow these instructions may result in serious damage or injury. 因為疏忽這些操作說明，而使用錯誤可能造成財產損失或嚴重傷害。
 CAUTION 注意	Mishandling due to failure to follow these instructions may result in danger. 因為疏忽這些操作說明，而使用錯誤可能造成危險。

SAFETY NOTES

安全注意事項

ALIGN

- Fly only in safe areas, away from other people. Do not operate R/C aircraft indoors or within the vicinity of homes or crowds of people. R/C aircraft are prone to accidents, failures, and crashes due to a variety of reasons including: lack of maintenance, pilot error, and radio interference. Pilots are responsible for their actions and damage or injury occurring during the operation or as a result of R/C aircraft models.
- Prior to every flight, carefully check all parts such as blades, screws, frame, arms, etc; ensure they are firmly secured and show no unusual wears, or unforeseen danger may happen.
- 遙控飛行機屬高危險性商品，飛行時務必遠離人群，禁止於室內飛行。人為組裝不當或未定期檢修造成的機件損壞、電子控制設備不良，以及操控上的不熟悉、都有可能導致飛行失控損傷等不可預期的意外，請飛行者務必注意飛行安全，並需了解自負疏忽所造成任何意外之責任。
- 每趟飛行前須仔細檢查機身各部位之零/配件/電子設備之性能是否正常，及無損耗老化現象，並確實將螺絲鎖緊才能升空飛行。並做好定期檢修，避免零件或電子產品異常所造成不可預期意外。



LOCATE AN APPROPRIATE LOCATION

遠離障礙物及人群

R/C aircraft can fly at high speed, thus posing a certain degree of potential danger. Choose a legal flying field consisting of flat, smooth ground without obstacles. Do not fly near buildings, high voltage cables, or trees to ensure the safety of yourself, others, and your model. Avoid location with magnetic and radio interferences. Please choose a legal flying field. Do not fly your model in inclement weather, such as rain, wind, snow or darkness.

遙控飛行機飛行時具有一定的速度，相對的也潛在著危險性，場地的選擇也相對的重要，請需遵守當地法規到合法遙控飛行場地飛行。必須注意周遭有沒有人、高樓、建築物、高壓電線、樹木等等，避免磁場干擾、外力訊號干擾及操控的不當造成自己與他人財產的損壞。請務必選擇在空曠合法專屬飛行場地。請勿在下雨、打雷、沙塵等惡劣天候下操作，以確保本身及機體的安全。

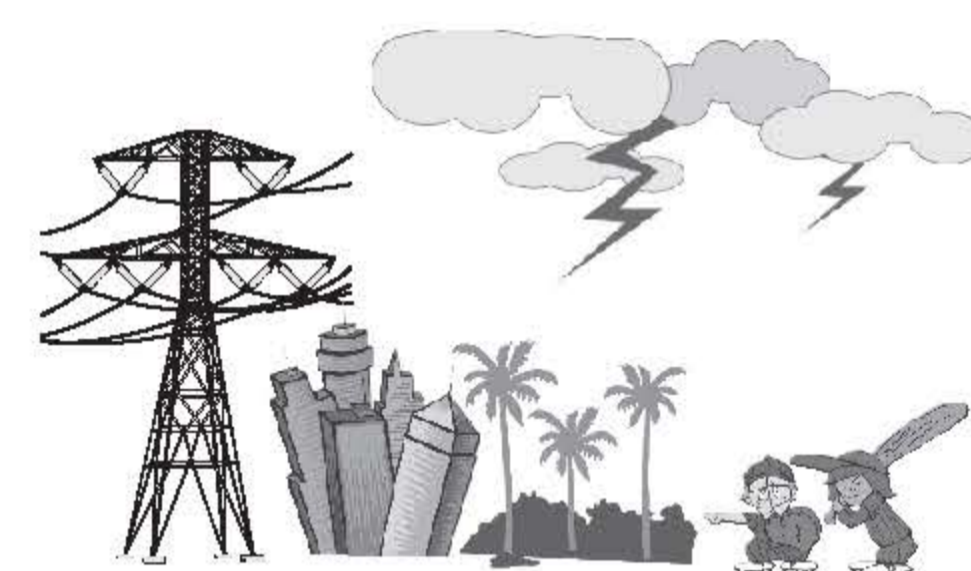

KEEP AWAY FROM HEAT

遠離熱源

R/C aircraft are made of various forms of plastics, such as carbon fiber and polyethylene. Plastics are very susceptible to damage or deformation from extreme heat and cold climate. Make sure not to store the model near any source of heat such as oven or heater. It is best to store the model indoors, in a climate-controlled, room temperature environment.

遙控飛行機多半是以碳纖維、PA纖維或聚乙烯、電子商品為主要材質，因此要盡量遠離熱源、日曬，以避免因高溫而變形甚至熔毀損壞的可能。



PREVENT MOISTURE

遠離潮濕環境

R/C aircraft are composed of many precision electrical components. It is critical to keep the model and associated equipment away from moisture and other contaminants. The introduction or exposure to water or moisture in any form can cause the model to malfunction resulting in loss of use, or a crash. Do not operate or expose to rain or moisture.

遙控飛行機內部也是由許多精密的電子零組件組成，所以必須絕對的防止潮濕或水氣，避免在浴室或雨天時使用，防止水氣進入機身內部而導致機件及電子零件故障而引發不可預期的意外！





FORBIDDEN 禁止 PROPER OPERATION 勿不當使用本產品

Do not attempt to modify the aircraft to alter its intended design. Please use only designated replacement parts listed in the manual to ensure its design structure integrity. Operate this product within its intended design parameters; do not overload it with excess cargo. This product is limited to personal hobby use, and pilot should be proficient with operation of this model. Follow all local law and ordinances when operating. Do not use this product for purposes which may violate others' personal privacy, and respect other's intellectual properties. Do not use this product for illegal purposes or beyond the bonds of common safety.

請勿自行改造加工，任何的升級改裝或維修，請使用亞拓產品目錄中的零件，以確保結構的安全。請確認於產品限界內操作，請勿過載使用，本產品為休閒娛樂專用之精密電子遙控飛行產品，僅限熟練遙控飛行器之個人使用，使用時請遵守當地法律規定，並嚴禁在任何違反公共安全區域操作，請勿利用本產品侵犯他人隱私/公開權、並尊重他人智慧財產權、著作權，且勿用於安全、法令外之其它非法用途。並充分了解您任何的使用與操作必須負完全的責任。

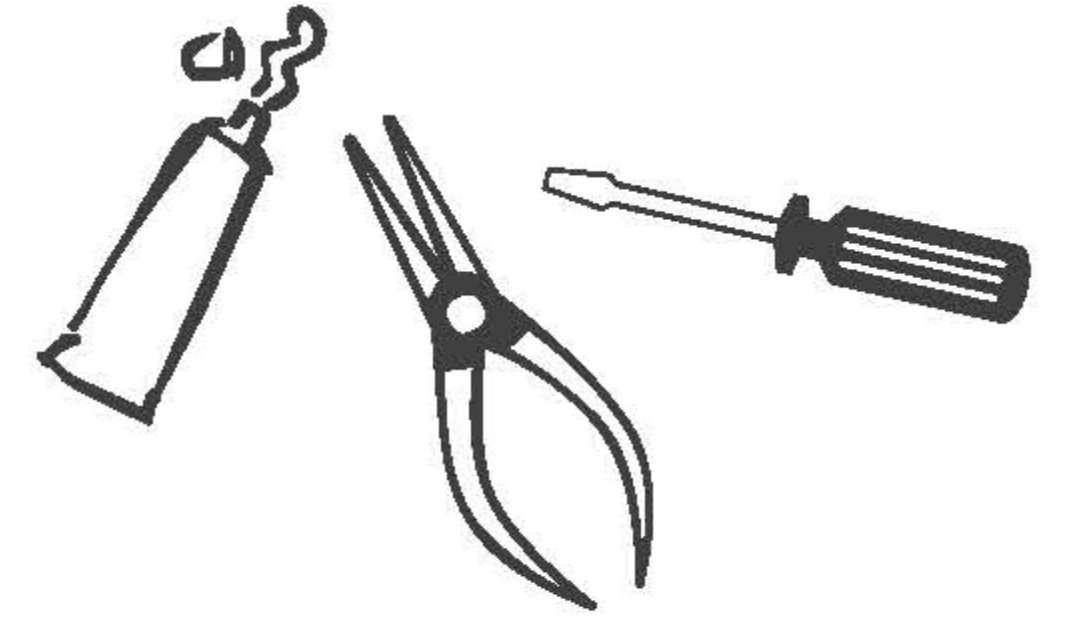

WARNING 警告 DO NOT FLY ALONE 避免獨自操控

Before turning on your model and transmitter, check to make sure no one else is operating on the same frequency. Frequency interference can cause your model, or other models to crash. The guidance provided by an experienced pilot will be invaluable for the assembly, tuning, trimming, and actual first flight or unforeseen danger may happen. (Recommend you to practice with experienced pilots or with computer-based flight simulator firstly.)

至飛行場飛行前，需確認是否有相同頻率的同好正進行飛行，因為開啓相同頻率的發射機將導致自己與他人立即干擾等意外危險。遙控飛行機操控技巧在學習初期有著一定的難度，要盡量避免獨自操作飛行，需有經驗的人士在旁指導，才可以操控飛行，否則將可能造成不可預期的意外發生。(勤練電腦模擬器及老手在場指導是入門必要的選擇)

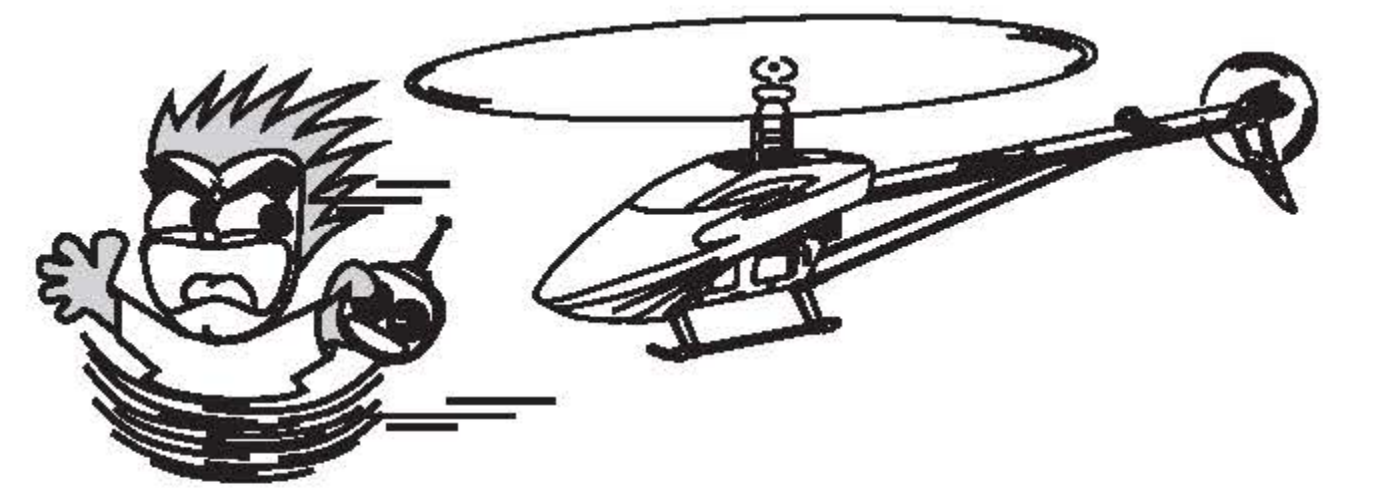

WARNING 警告 SAFE OPERATION 安全操作

Operate this unit within your ability. Do not fly while feeling impaired, as improper operation may result in danger. Never take your eyes off the model or leave it unattended while it is turned on. Immediately turn off the model and transmitter when you have landed the model.

請於自己能力內及需要一定技術範圍內操作這台遙控飛行機，過於疲勞、精神不佳或不當操作，意外發生風險將可能會提高。不可在視線範圍外飛行，降落後也請馬上關掉遙控飛行機和遙控器電源。



CAUTION 注意 ALWAYS BE AWARE OF THE ROTATING BLADES 遠離運轉中零件

During the operation of the multicopter, the rotor will be spinning at a high rate of speed. The blades are capable of inflicting serious bodily injury and damage to surrounding properties. Be conscious of your actions, and careful to keep your face, eyes, hands, and loose clothing away from the blades. Always fly the model a safe distance from yourself and others, as well as surrounding objects.

遙控飛行機主旋翼/螺旋槳運轉時會以高轉速下進行，在高轉速下的主旋翼/螺旋槳會造成自己與他人在身體上或環境上的嚴重損傷，請勿觸摸運轉中的主旋翼/螺旋槳，並保持安全距離以避免造成危險及損壞。

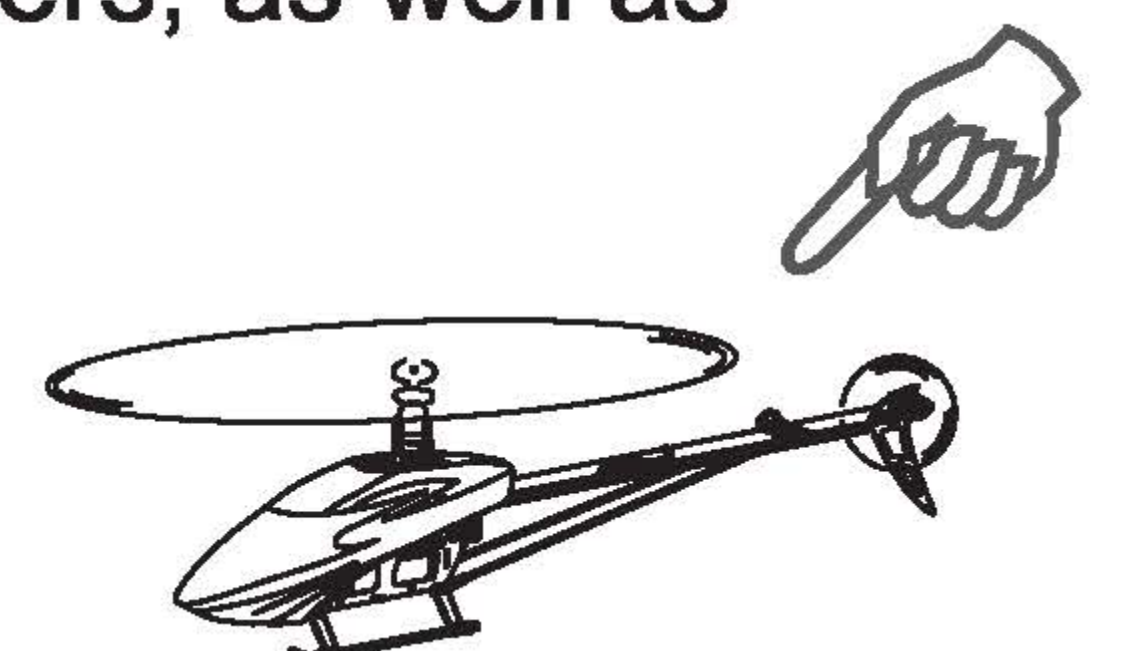

MICROBEAST PLUS SAFETY NOTES

MICROBEAST PLUS 安全注意事項

ALIGN



Radio controlled (R/C) helicopters are not toys! The rotor blades rotate at high speed and pose potential risk . They may cause severe injury due to improper usage . It is necessary to observe common safety rules for R/C models and the local law . You can gather information from your local R/C model club or from your national modelers association .

遙控直昇機不是玩具！螺旋槳高速旋轉帶來的潛在風險相當高，它們可能會導致嚴重的傷害，一切的使用要符合並遵守共同的安全規則，並且遵守當地的無線電遙控模型協會制度規定。您可以從當地的模型俱樂部或從您的國家航模運動協會取得相關資訊。



Pay attention to your own safety and the safety of other people and property in your vicinity when using our product . Always fly in areas away from other people . Never use R/C models in close proximity to housing areas or crowds of people . R/C models may malfunction or crash due to several reasons like piloting mistakes or radio interference, and cause severe accidents . Pilots are fully responsible for their actions, and for damage or injuries caused by the usage of their models .

注意自己與他人以及財物的安全，在您使用我們的產品時，請您遠離建築與人群。遙控直昇機可能在飛行中出現任何意外，可能是飛行員的操控失誤，或者是無線電干擾，並導致嚴重事故的發生。飛行員必須為自己的行為負完全責任，以及所造成的任何損害。



Please read the following instructions thoroughly before the first use of your MICROBEAST PLUS and setup the system carefully according to this manual . Allow sufficient time for the setup procedure and check each step carefully . Watch for a mechanically clean and proper build of your helicopter . A wrong system setup can lead to a serious accident and damage to the model .

設置 MICROBEAST 時請仔細閱讀以下說明，並且一定要留出足夠的時間來仔細設定，並小心檢查每一個步驟。除此之外，也要特別注意無平衡翼旋翼頭的組裝是否正確，稍有差錯或機械故障，可能導致嚴重的事故發生。



Radio controlled (R/C) models consist of several electrical components . It is therefore necessary to protect the model from moisture and other foreign substances . If the model is exposed to moisture this may lead to a malfunction which may cause damage to the model or a crash . Never fly in the rain or extremely high humidity .

無線遙控模型，是藉由許多電子零件組裝而成，因此有必要保護這些脆弱的電子零件，例如防水、防塵等工作。如果遙控模型受潮可能導致故障，請絕對不要在雨天或濕度極高的氣候中飛行。



When operating the helicopter with a MICROBEAST PLUS ensure there is a sufficiently large and stable receiver power supply . Because of the direct coupling of the rotor blades to the servos, without the use of a flybar mixer, the servos are exposed to increased actuating forces . In addition, because of the intermediary electronic gyro system, the servos are driven more often than with traditional use . These factors can make the power consumption increase a lot compared to a flybar helicopter . When the supply voltage falls below 3,5 volts for a short amount a of time, the system will power off and reboot . In this case a crash of the helicopter is unavoidable .

操控您的直昇機時，請確保 MICROBEAST PLUS 有一個充足、穩定的接收器電源。由於十字盤伺服器直接連接十字盤、主旋翼，不像傳統貝爾希拉混控旋翼頭那樣的省力，所以請特別注意！無平衡翼直昇機使用的伺服器會顯得特別的耗電，請務必確定您的供電系統有足夠的供電能力。若電壓低於 3.5V，即使是很短暫的時間，系統將關閉並重新啟動。在這種情況下，墜機是很難避免的。



Do not expose the MICROBEAST PLUS system to extreme variations in temperature . Before powering up the system, wait some time so that the electronics can acclimatize and any accumulated condensation is able to evaporate .

請勿讓 MICROBEAST PLUS 在極端溫度變化的環境下飛行，例如從溫暖的室內短時間帶到寒冷的室外，環境轉換至少需有 20 分鐘以上的緩衝適應，讓電子零件上的水氣凝結揮發掉，才能夠通電開機。



The sensors of MICROBEAST PLUS consist of highly sensitive electromechanical components . These can be damaged due to moisture or mechanical or electrical impact . Do not continue using this product, if it has been exposed to such influences, e . g . due to a crash of the model or due to overvoltage caused by a defective receiver power supply . Otherwise a failure may happen any time .

MICROBEAST PLUS 包括高度敏感的電子元件，它可能在潮濕的環境中、機械或電子的衝擊中受到損害。如果您的模型已經遭受到撞擊，或者接收器的電源供應不穩定等等，請不要繼續使用 MICROBEAST PLUS，否則故障會不斷發生。



When operating electric helicopters make sure that the electric motor cannot start inadvertently during the setup procedure . Particularly pay attention if using a single-line receiver and if the ESC is connected directly to the MICROBEAST PLUS . We recommend disconnecting the electric motor from the ESC during the setup procedure . Prior the first usage please slide the motor/pinion away from the main gear, then check that the motor does not start inadvertently when the receiver is switched on .

操作電動直昇機時，請確保電動馬達不會在安裝過程中無意間啟動。尤其要特別注意，如果您使用的是單線連接接收器，且 ESC 直接連接到 MICROBEAST PLUS。我們建議在安裝過程中 ESC 不要連接電動馬達。在第一次使用之前，請滑動馬達/齒輪以遠離主齒輪，然後檢查馬達不會在開啓接收器時被啟動。



When operating the RPM Governor feature of MICROBEAST PLUS Pro-Edition it is essential to ensure that the motor cannot start by accident when making adjustment or performing preparations to start the engine . Carefully read this manual and make sure you fully understand how the RPM Governor feature is operated before making any adjustments . Also make sure the motor does not start when the radio link is interrupted or when you switch on the transmitter initially. With electric driven models do not dock the motor to the main gear unless all necessary adjustment procedures have been finished. Always maintain sufficient safety distance to the motor and other rapidly rotating components of the helicopter.

操作 MICROBEAST PLUS Pro-Edition 的 RPM 定速模式時，請確保馬達不會在調整或準備啟動引擎過程中無意間被啟動。調整前請仔細閱讀本說明書了解 RPM 定速模式的操作特性。並請確保在開啓或關閉遙控器時，馬達不會被啟動。使用電動直昇機時請不要連接馬達跟主齒輪，除非確定所有必要的調整已經完成。直昇機內的馬達及其他快速轉動的零件必須保持足夠的安全間隙。



MICROBEAST PLUS with AttitudeControl can be used as a flying aid for beginners as the reaction of the helicopter to stick inputs can be limited and as an electronic control circuit can help to stabilize the helicopter. However, this does not provide that the helicopter can always be flown safely! By incorrect control inputs the helicopter still may crash or be placed in a position in which the pilot becomes disoriented even when using AttitudeControl. In addition, the helicopter can drift due to external influences and it is not guaranteed that the artificial horizon of the device can stabilize the helicopter at any time and recover from any orientation. Influences such as temperature fluctuations or vibrations may cause incorrect results and distort the position calculation of the system in consequence. There is no guarantee that the system will always work correctly. Only the pilot is responsible for the control of the helicopter and thus also for the use of the system. You must always be able to turn off the system immediately and be able to take over full control of the helicopter.

MICROBEAST PLUS 的姿態模式可以輔助初學者飛行，因為此模式可限制直昇機的搖桿輸入反應，且電子控制電路有助於穩定直昇機。但是，這並不保證直昇機可以安全飛行！不正確的指令輸入，即使是在姿態模式下，直昇機仍可能會摔機或者迷失方向。此外，直昇機可能受外部影響而漂移，我們無法保證可以隨時讓直昇機能從任何方向恢復並自平。其他如氣溫的變化或振動都可能影響系統而會導致不正確的結果，造成系統計算失真。我們無法保證此系統總是能正常工作。只有飛手能負責直昇機的控制，以及正確使用本系統。請確保您能隨時立即關閉此平衡系統，並取回直昇機控制權。



We suggest you to seek the support of an experienced helicopter pilot before you undertake the first flight of your model. Additionally, flight training with a R/C simulator can help make flying easier and more enjoyable. Ask your local dealer if you need technical support or if you observe problems during the usage of our system.

我們建議您尋求具有足夠經驗的遙控直昇機玩家，然後再進行第一次的 MICROBEAST PLUS 搭配飛行。此外，飛行訓練用的 R/C 模擬器可以幫助使飛行更簡單，更有樂趣。如果您有任何技術支援或系統使用的問題，請與當地代理連絡。



AttitudeControl can help to facilitate flying of model helicopters by briefly passing over control to the system if the pilot becomes disoriented. By using the built-in artificial horizon the helicopter can be brought to a nearly horizontal position so that the pilot gains time to reorient. Thus there can be no assurance that the model is saved from a crash in general. Depending on the current attitude and the speed of the model and depending on how fast the AttitudeControl is activated, the model may crash before or while the system tries to recover. In addition, the helicopter can drift due to external influences and it is not guaranteed that the artificial horizon of the device can stabilize the helicopter at any time and recover from any orientation. Influences such as temperature fluctuations or vibrations may cause incorrect results and distort the position calculation of the system in consequence. Strictly observe the general safety rules for dealing with RC models and do not totally rely on the system. The pilot is responsible for the control of the helicopter and thus also for the use of the system. You must always be able to turn off the system immediately and be able to take over full control of the helicopter.

如果飛手在飛行中迷失方向，姿態模式可以快速控制系統，幫助操控直昇機。藉由使用內建自平功能，使直昇機接近水平位置，讓飛手有時間重新調整正確的方向。但仍不保證可以拯救失控的直昇機，系統介入的速度及反應主要是根據直昇機當時的姿態和速度而定，即便如此，該直昇機仍可能會在系統嘗試恢復時或之前摔機。此外，直昇機可能受外部影響而漂移，且無法保證可以隨時讓直昇機能從任何方向恢復並自平。其他如氣溫的變化或振動都可能影響系統而會導致不正確的結果，且造成系統計算失真。我們無法保證此系統總是能正常工作。只有飛手能負責直昇機的操控，以及正確使用本系統。請確保您能隨時立即關閉此平衡系統，並取回直昇機控制權。

QUICKSTART GUIDE V4.2

V4.2 快速導覽

ALIGN

Dear customer,

Thank you for purchasing our product.

MICROBEAST PLUS is a high-end flybarless system for RC helicopters that has been developed in Germany using latest technology and setting high standards. This system can be used with nearly any size and type of RC helicopters and besides using it as flybarless stabilization system it offers additional features that can make flying helis even easier and comfortable.

To program MICROBEAST PLUS we consciously decided against using a tiny display that might be hard to read or using an external programming device such as a smart phone or PC software. The "EasySetup" concept allows to setup the helicopter in a very short amount of time and without the need of additional devices which you might have forgotten at home when on the flying field. You can setup your helicopter anytime and anywhere and you're ready for take off within a few minutes.

This Quickstart Guide is a clearly arranged guide that will lead you step-by-step through the basic flight setup. Please follow this guide carefully and make sure to read the attached safety notes. For a detailed instruction manual and a lot more details, tips, tricks and notes about the product please visit

WIKI.BEASTX.COM

StudioX allows to edit, save and load the device setup by using a PC. Additionally it can be used to register your device and acquire optional features. Also it allows to perform very special setups like such as a virtual swashplate rotation for multiblade rotorheads. To connect your MICROBEAST PLUS to the computer the optional available USB2SYS interface is required.

StudioX can be downloaded from:

STUDIOX.BEASTX.COM

親愛的客戶：

感謝您使用 MICROBEAST PLUS 無平衡翼控制系統！

MICROBEAST PLUS 採用德國最新技術和最高標準，是專為遙控直昇機設計的無平衡翼控制系統。此系統幾乎可以搭配任何尺寸和類型的遙控直昇機，不僅作為無平衡翼穩定系統，它還提供額外的功能，讓直昇機飛行更加輕鬆及自在。

在編寫 MICROBEAST PLUS 的過程中，我們發現若程式必須透過一個小的視窗，如 PC 軟體或手機 APP 介面來設定，可能很難閱讀或記憶，所以我們決定使用 "EasySetUp" 的概念來簡化設定編程。這樣的設計是為了讓您在很短的時間內，即使在飛行場中，沒有相關的設備，也可以輕鬆、簡單地依您的需求隨時更改設定，使您的直昇機能在幾分鐘之內迅速升空。

本快速入門指南將以非常簡單且明確的方法，一步一步帶領您完成基本的飛行設定，並請務必仔細閱讀其安全注意事項。關於詳細的使用說明書和更多的細節、技巧和注意事項，請瀏覽以下網站。

WIKI.BEASTX.COM

StudioX 允許您透過 PC 來編輯、保存此無平衡翼系統的設定。它可以用來註冊您的設備和獲得更多的功能選項。此外，透過這個裝置，能允許您執行非常特別的設定，例如多旋翼的虛擬十字盤。同時您需要一條 USB2SYS (另購品)來連接電腦及 MICROBEAST PLUS。

請至以下連結下載 StudioX

STUDIOX.BEASTX.COM

This guide only is intended to be used with MICROBEAST PLUS firmware version 4.2.x!

You can see what firmware version your MICROBEAST PLUS is running when it is powered on. First the device carries out a brief LED test. Then for about 3 seconds the Status-LED lights red while the Menu-LEDs A - G display the first digit of the firmware version and the LEDs H - N the second digit of the firmware version.

本快速指南所描述的調整內容，只適合 MICROBEAST PLUS Version 4.2.x 版本！

當開機時，您可以透過 MICROBEAST PLUS 得知當前的主程式版本。首先，系統會執行簡單的 LED 燈測試。約 3 秒鐘後，Status-LED 燈就會亮起紅燈。而 Menu-LED 燈號 A-G 顯示第一位軟體版本，燈號 H-N 顯示了次要版本(第二位數)。

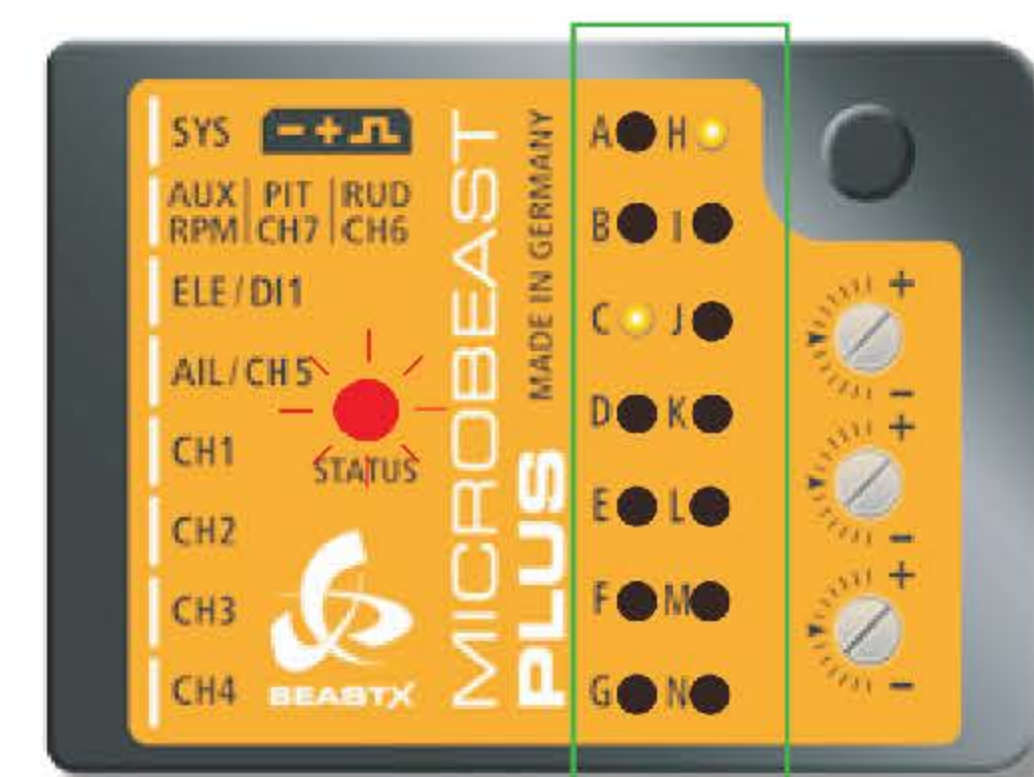

Firmware version: 4.2.x

In the left row Menu-LED C stands for major version "4". In right row Menu-LED H shows minor version "1".

主程式 V4.2.x:

在左排選單中，LED 燈號 C 顯示了主程式的版本 "4"。右排 LED 燈號 H 表示次要版本為 "1"。

1 HARDWARE INSTALLATION

硬體安裝方法

ALIGN

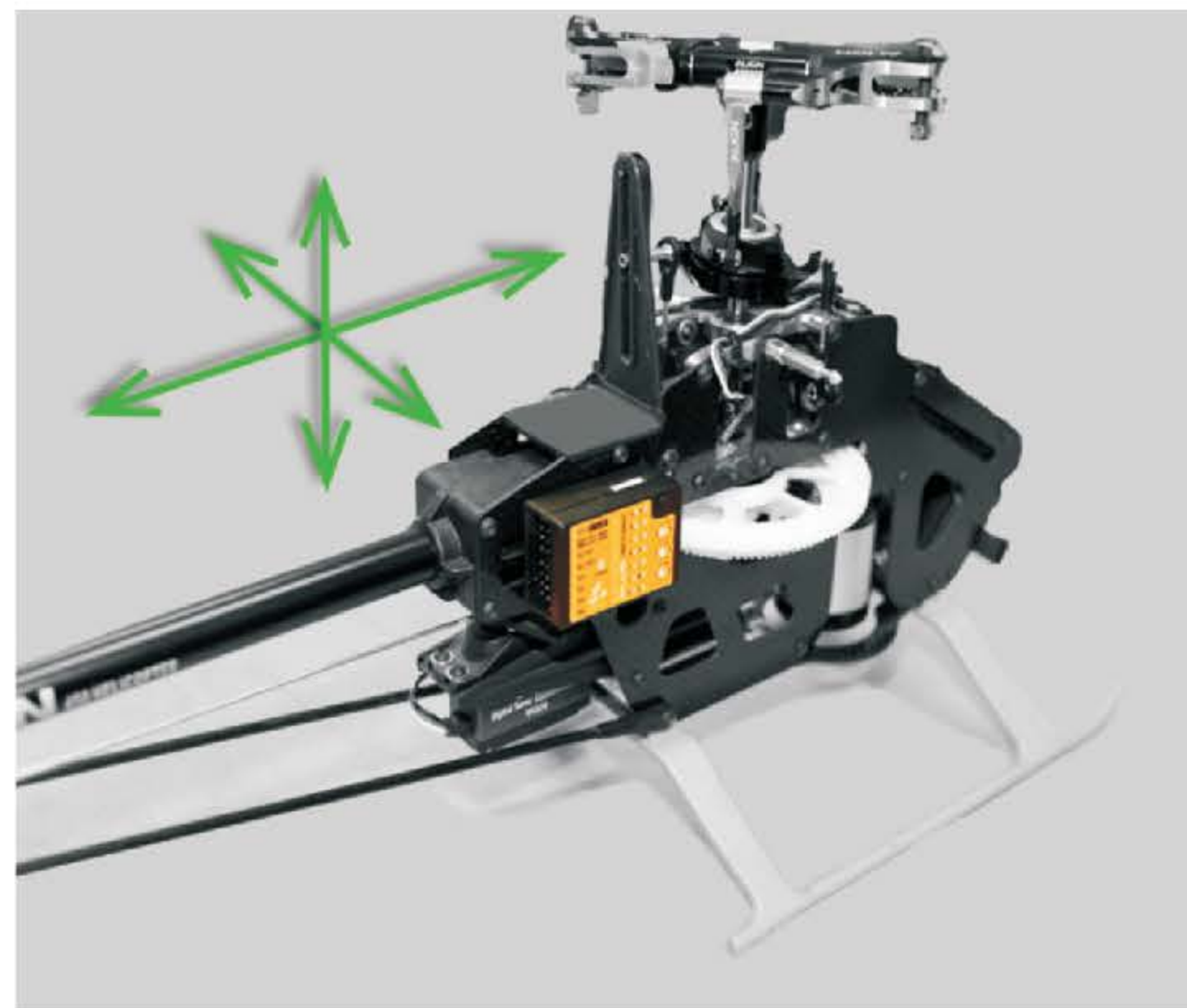
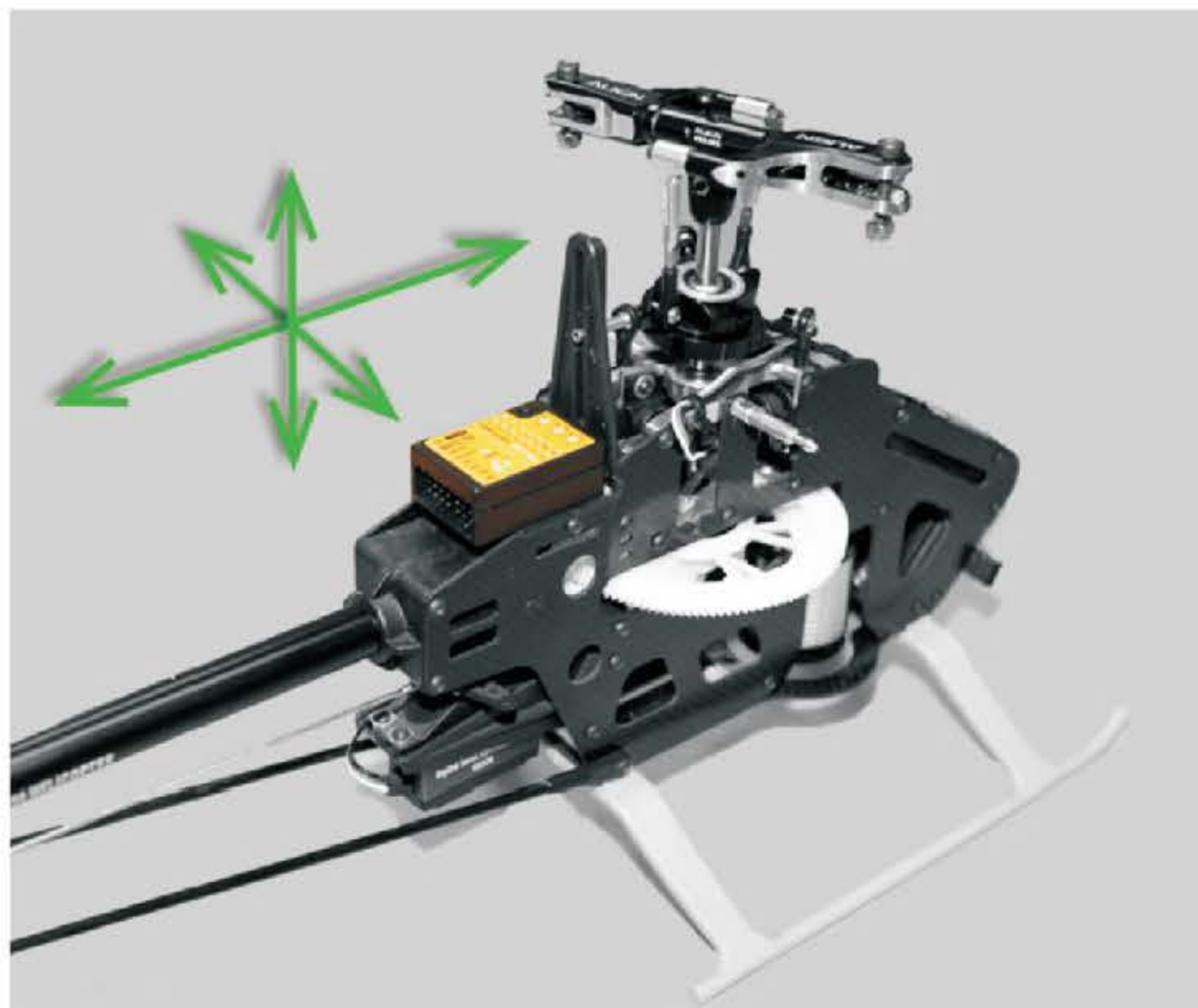

You can position MICROBEAST PLUS flat or upright on the helicopter. The large socket must point to the front or to the rear of the helicopter.

MICROBEAST PLUS 可以平放或倒置安裝於直昇機上。最大的插口必須對準直昇機的前方或後方。最小的白色插口需對準 X 軸。

The small white socket must be aligned with the longitudinal axis. The sensor axis (housing edges of the device) must be aligned exactly parallel to all three rotation axis of the helicopter. However, it is allowed to position the device offset from the rotation axis.

傳感器軸(MICROBEAST PLUS 的殼體邊)必須準確地平行於直昇機的三個旋轉軸(主軸、橫軸、尾傳動齒輪軸)。然而，其安裝位置在旋轉軸的範圍內即可。

In summary there are 8 mounting orientations possible:

- 1.flat, sticker on top, socket pointing to front*
- 2.upright, button up, socket pointing to front
- 3.flat, sticker showing to ground, socket pointing to front
- 4.upright, button down, socket pointing to front
- 5.flat, sticker on top, socket pointing to rear
- 6.upright, button up, socket pointing to rear
- 7.flat, sticker showing to ground, socket pointing to rear
- 8.upright, button down, socket pointing to rear

總共有八種不同安裝方向供您選擇：

- 1.平放 / 貼紙朝上側 / 插口朝飛行方向*。
- 2.垂直 / 按鈕朝上側 / 插口朝飛行方向。
- 3.平放倒置 / 貼紙朝底部 / 插口朝飛行方向。
- 4.垂直倒置 / 按鈕朝底部 / 插口朝飛行方向。
- 5.平放 / 貼紙朝上側 / 插口朝尾管。
- 6.垂直 / 按鈕朝上側 / 插口朝尾管。
- 7.平放倒置 / 貼紙朝底部 / 插口朝尾管。
- 8.垂直倒置 / 按鈕朝底部 / 插口朝尾管。

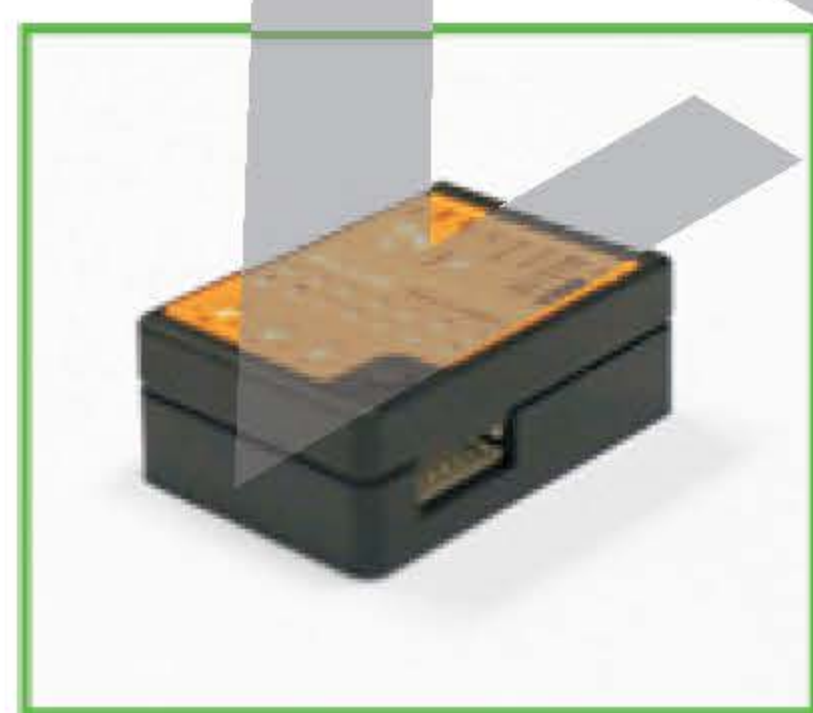

1.



2.



3.



4.



5.



6.



7.



8.

Flight Direction
飛行方向

Use one of the supplied 3M gyro pads to stick the device to your helicopter. The device housing must not directly touch the chassis of the helicopter. When connecting and laying out the servo and receiver wiring later onwards please make sure the wires do not pass tension to the MICROBEAST PLUS. It is not recommended to bundle or tie down the leads close to the MICROBEAST PLUS device.

請使用隨貨附贈的 3M 陀螺儀專用泡棉來固定 MICROBEAST。安裝 MICROBEAST PLUS 時，請勿將連接線拉得太緊，請確保 MICROBEAST PLUS 本體能保持足夠的晃動空間，這樣才不會因為連接線太緊而將震動傳遞到感應器。也不建議在靠近 MICROBEAST PLUS 本體的地方綑綁或繫緊束帶。另一方面，所有線材皆須確實接好，以避免飛行時 MICROBEAST PLUS 因離心力而脫落。特別是，請不要在接近 MICROBEAST PLUS 的連接線上使用任何熱縮套管、保護套管來捆綁連接線。這會使電線僵硬不靈活，引起振動，進而影響到 MICROBEAST PLUS 的功能。

2 CONNECTING THE RECEIVER

接收器連接

ALIGN

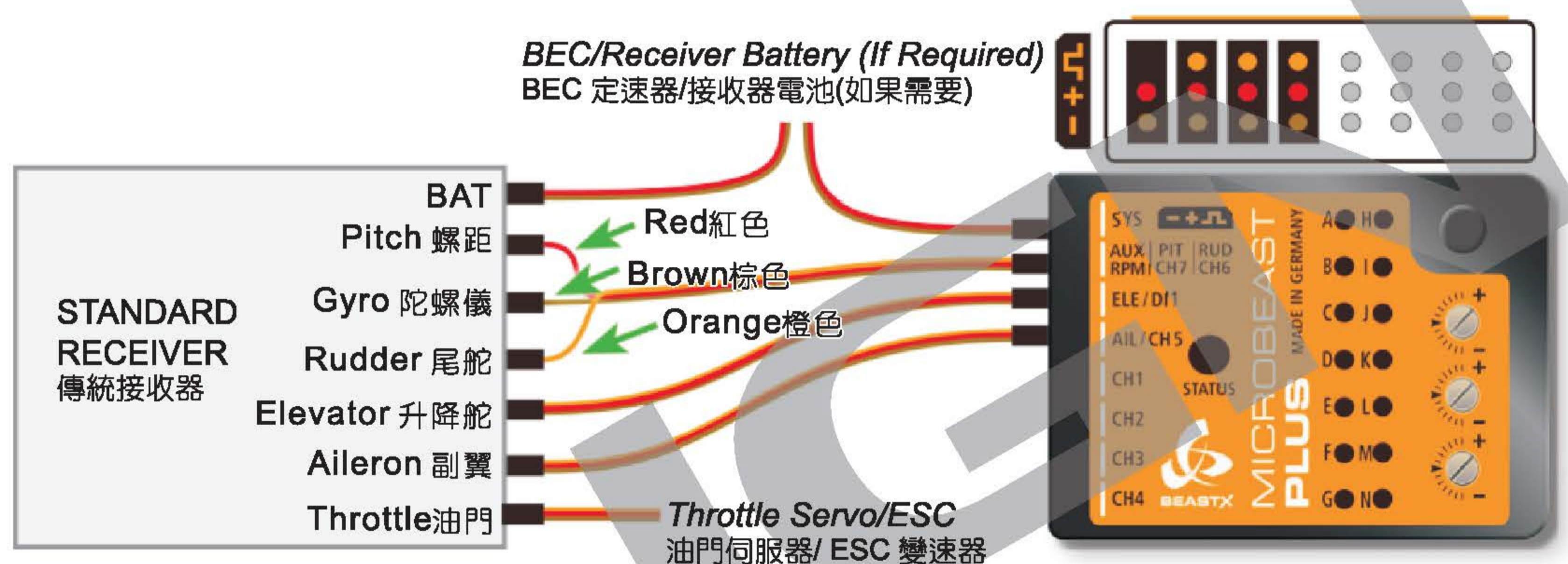

The illustrations are only intended as examples!

The function assignment of the transmitter determines which channel on the receiver controls which function.

此圖僅供參考
遙控器通道分配決定了個別接收器在遙控器通道上的控制功能。

The assignment of functions to the radio channels is mentioned in the manual of your radio system. Also you may find out the function assignment by checking your transmitter's servo monitor. The connectors of MICROBEAST PLUS are assigned to the functions as follows:

AIL|CH5 = Aileron, ELE|DI1 = Elevator, RUD (orange wire) = Rudder, PIT (red wire) = Thrust, Aux (brown wire) = Gyro gain

The wires for aileron and elevator additionally transfer the power between MICROBEAST PLUS and receiver.

Using a Single-Line receiver all channels/functions are transferred by one single connection wire. This allows to use even more than 5 channels, i. e. for controlling the nitro RPM Governor, AttitudeControl function and/or additional servo output channels.

遙控器的通道分配，請參考遙控器說明書。您也可以在遙控器的伺服器螢幕上查看功能分配。MICROBEAST PLUS 的通道功能分配如下：

AIL|CH5 = 副翼；ELE|DI1 = 升降舵；RUD (橙色線) = 尾舵；PIT (紅色線) = 油門；Aux (棕色線) = 陀螺感度

副翼和升降舵的連接線有額外的供電功能，可提供 MICROBEAST PLUS 及接收器電源。

使用單線連接接收器時，所有通道/功能都是由一條連接線來傳送。它允許超過 5 個以上的通道分配，可分配功能如：引擎 RPM 定速模式，姿態模式或額外的伺服器輸出通道。

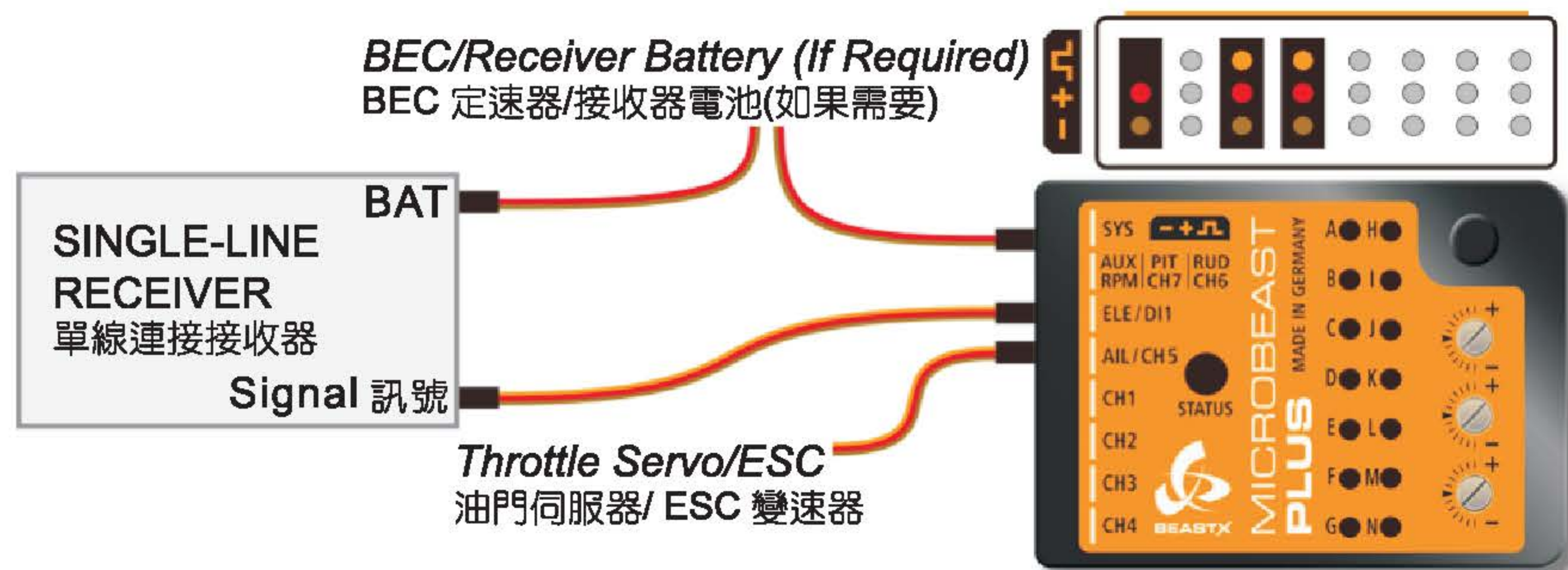

Supported receivers/transmission protocols:

- SRXL: JR XBus (Mode B), Multiplex SRXL (V1+V2), Jeti UDI, Graupner/SJ HOTT SUMD, Spektrum SRXL
- Futaba SBUS
- Spektrum remote satellite (DSM2/DSMX)
- JR DMSS remote satellite (JR RJ01)
- PPM serial signal (SPPM)

支援接收器/遙控器類型：

- SRXL: JR XBus (Mode B), Multiplex SRXL (V1+V2), Jeti UDI, Graupner/SJ HOTT SUMD, Spektrum SRXL
- Futaba SBUS
- Spektrum 衛星天線 (DSM2/DSMX)
- JR DMSS 衛星天線 (JR RJ01)
- PPM 系列信號 (SPPM)

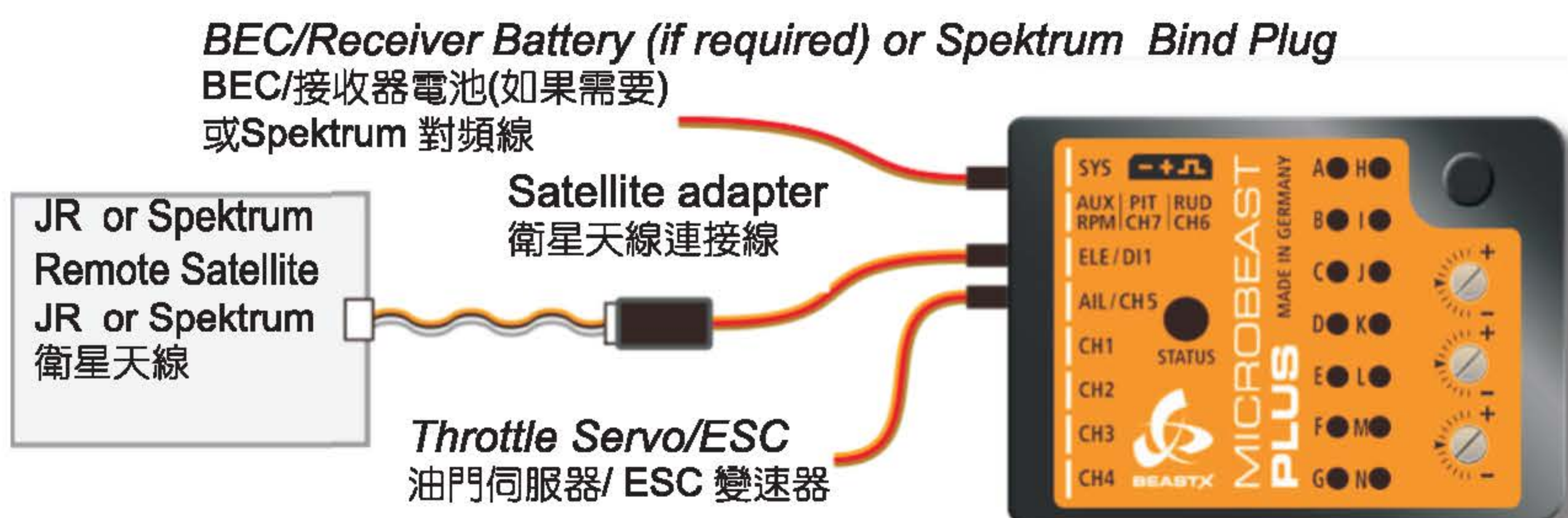

Using a single remote satellite is only recommended for 450 size helis or smaller! For larger helis you may use a SRXL compatible Single-Line receiver.

若您使用的是單線衛星天線，建議只使用在 450 級或更小的直昇機上！若您的直昇機是較大的機型，建議您使用 SRXL 相容單線連接接收器。

Always make sure the power supply is stable and dimensioned sufficiently for the intended application. If possible always connect the power source directly to MICROBEAST PLUS. Especially when using standard size servos it is recommended to use more than one power supply cable in parallel to preserve a stable voltage and to reduce power loss due to connection resistance. The additional supply cables may be connected to free receiver ports. We recommend to use MICROBEAST PLUS HD which offers a low resistant high-power input and which is well suited for larger model helicopters.

To initiate bind procedure on a single Spektrum remote satellite connect the Spektrum bind plug to SYS port. When using a DSMX remote satellite push and hold the button and turn on power while still holding the button down. The LED on the satellite will flash together with Menu LED H on the MICROBEAST PLUS. When binding a DSM2 remote satellite do not touch the button but only power on the device. The LED on the satellite will flash together with Menu LED N. Initiate the bind procedure on the transmitter. Power off and remove the bind plug when finished successfully.

To bind the JR RJ01 remote satellite initiate the bind procedure on the transmitter and power on the MICROBEAST PLUS. The remote satellite will bind instantly. Connecting a bind plug or similar is not necessary.

請確定使用的電源規格符合系統要求。如果可能，請給 MICROBEAST PLUS 一個直接的電源。尤其是在使用標準伺服時，建議您使用一個以上的供電連接線，並使其保持平行而穩定的電壓，以減少因電流傳輸產生電阻而損耗功率。此外，連接線可插到一個閒置的接收機端口。我們建議您使用 MICROBEAST PLUS HD 它提供了一個低阻抗高功率的輸入插槽，非常適合大型直昇機。

若使用 Spektrum 衛星接收天線，初始對頻時，請將 SPEKTRUM 的對頻金鑰插入 MICROBEAST PLUS 的〔SYS〕插槽。若使用 DSMX 衛星天線時，進入對頻模式後，請長按 MICROBEAST PLUS 上的按鈕並接通電源，直到接收器的 LED 燈和 MICROBEAST PLUS 設定選單第 H 點旁的 LED 燈同時閃爍，此時可鬆開按鈕，然後對頻接收器和遙控器，對頻成功後接收器的 LED 燈將保持恆亮。若使用 DSM2 衛星接收天線，進入對頻模式後，請不要按按鈕，只需開啓電源即可，直到衛星天線的 LED 燈和 MICROBEAST PLUS 設定選單第 N 點旁的 LED 燈同時閃爍，此時鬆開按鈕，然後對頻接收器和遙控器，對頻成功後，接收器的 LED 燈將保持恆亮。這是在遙控器的對頻過程，完成後，請關閉電源並移除對頻金鑰。

若使用 JR RJ01 衛星接收天線、遙控器和 MICROBEAST PLUS，初始對頻時，衛星接收天線會保持對頻，對頻金鑰或類似的工具是不需要的。

3 MICROBEAST PLUS HD

MICROBEAST PLUS HD

ALIGN

Input voltage range: 3,5 -8,4 Volts.

MICROBEAST PLUS HD in first line was designed for 550 size helis and larger which use standard size servos with high current consumption. Here you can connect the power supply directly to the additional high-power input which reduces voltage loss due to contact and wiring resistance significantly when high currents are flowing. Always use the supplied power cable as connector between battery and MICROBEAST PLUS HD. It is not recommended to directly plug in the battery at the device. Continuous plugging and unplugging can cause the overlying servo plugs getting unplugged accidentally or cause the adhesive gyro pad to get loose!

Receiver and servo plugs are connected to the ports on top of the unit, similar as described for the standard (non-HD) MICROBEAST PLUS.

輸入電壓: 3.5 -8.4 Volts.

MICROBEAST PLUS HD 是專為使用具高電流的標準伺服器 550 級以上的大型直昇機所設計的無平衡翼系統。在這裡，您可以直接連接一個額外的高功率輸入電源，以降低電壓損失，因為當高電流傳輸時會產生異常的高電阻。請永遠使用 MICROBEAST PLUS HD 專用耐高壓連接線，來連接電池和 MICROBEAST PLUS HD。不建議將電池的插頭直接插入 MICROBEAST。因為不斷的插拔接頭可能讓專用泡棉的雙面膠失去黏性而導致意外發生。

接收器和伺服器的接頭請連接到 MICROBEAST PLUS HD 上蓋方向的輸出接口，和 MICROBEAST PLUS 的接法相類似，請參考其說明。

Receiver Battery or BEC
接收器電池或 BEC 定速器



High-power Connector
高功率連接器

Switch
專用開關

Switch Plug
(Polarity not Relevant)
開關插頭(無關乎極性)

Using the switch is optional. The device can also be operated without the switch.

Anyhow, never connect anything else than the switch to the switch port!

專用開關是另購品。沒有此開關也可以操作 MICROBEAST PLUS。

無論如何，除了 MICROBEAST PLUS 專用開關外，請勿將其他開關插入此開關插孔。

CAUTION
注意

When switched off MICROBEAST PLUS HD consumes a very low amount of standby current. Therefore always completely disconnect the battery from the system if you do not use the model for a extended period of time to prevent the supply battery from getting discharged and damaged in consequence.

當關閉 MICROBEAST PLUS HD 時，系統仍會消耗一些非常低的電流。因此，如果停止飛行，請記得將電池插頭從系統移除，以防止電池過放造成損壞。

CAUTION
注意

MICROBEAST PLUS HD does not supply an internal voltage regulation! The voltage that is applied to the high power connection port will directly be passed to the servo and receiver connections. Only use electronic components (servos and receiver) that are designed for your power source.

MICROBEAST PLUS HD 不會自行調節電壓！高電壓會供應到高功率的接口上，然後直接傳遞給伺服器和接收器使用。請使用高電壓專用伺服器和接收器。

CAUTION
注意

Using the high power connection port is not a must. You can also use MICROBEAST PLUS HD in a conventional manner by powering the unit from the receiver ports in the top row. However, using the electronic power switch system is not possible then.

使用高功率的連接端口並不是必須的。您還能以傳統的方式，利用位於上蓋方向的接收器端口來供應電源給 MICROBEAST PLUS HD。若使用此方法供電，就不能使用電子開關系統了。

4 PREPARING YOUR TRANSMITTER

準備遙控器

ALIGN

Create a new helicopter model memory in your transmitter that supplies different flight modes for controlling throttle, pitch and the tail gyro gain in different flight situations.

在您的遙控器上設置並儲存一個新的直昇機模式，它支援不同的飛行模式，在不同的情況下，控制油門，螺距和尾舵陀螺儀感度。

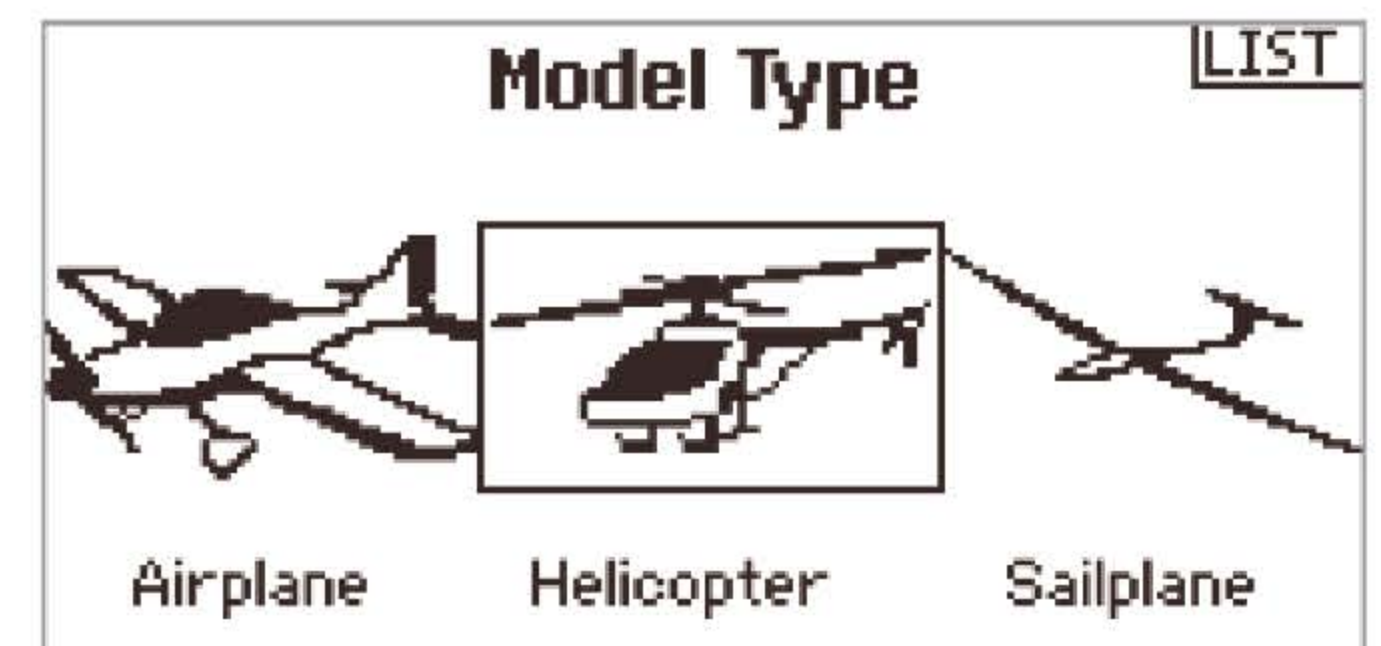
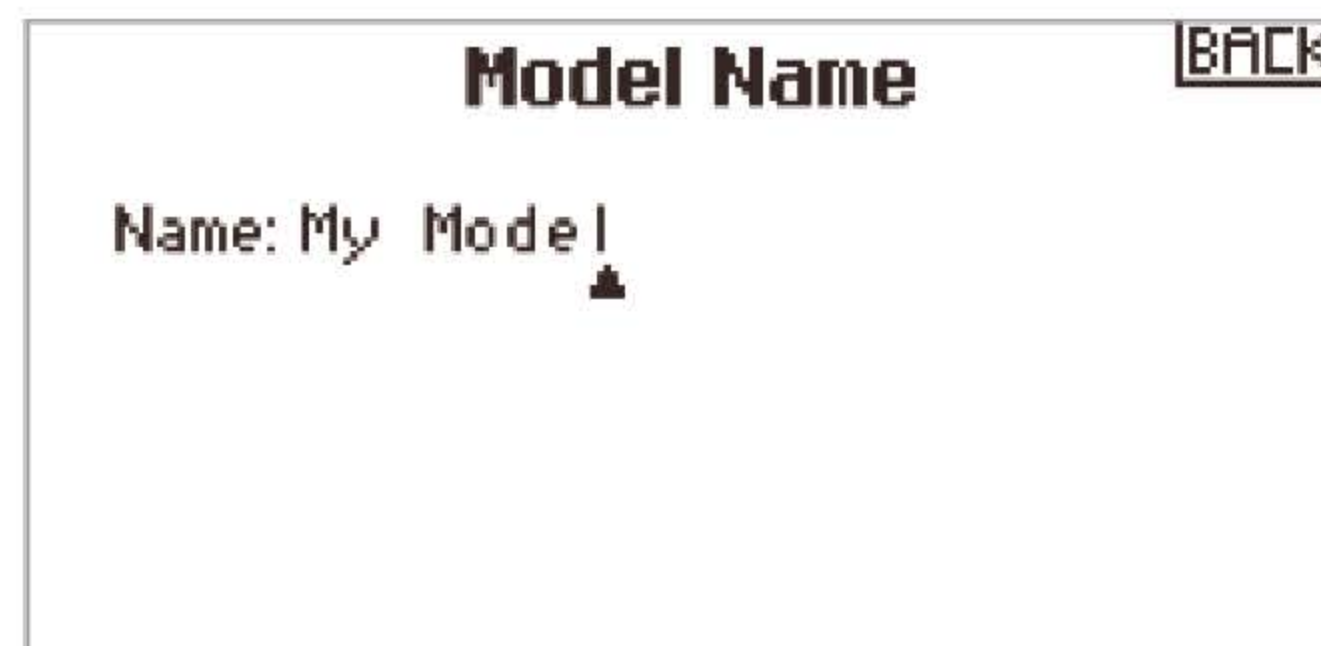

You must not use any mixing functions on the output channels! Especially it is not allowed to use mixing functions for the swashplate servos. Deactivate all output channels that are not used. In the basic configuration we only need pitch, aileron, elevator, rudder, throttle and one channel to adjust the tail gyro gain.

請注意！您不能在輸出通道上使用任何混控功能！特別要注意的是，十字盤的伺服器不允許使用混控功能。請關閉任何閒置的輸出通道。系統對基本通道的配置，只需要螺距、副翼、升降舵、方向舵、油門和一個通道來調整尾舵陀螺感度。

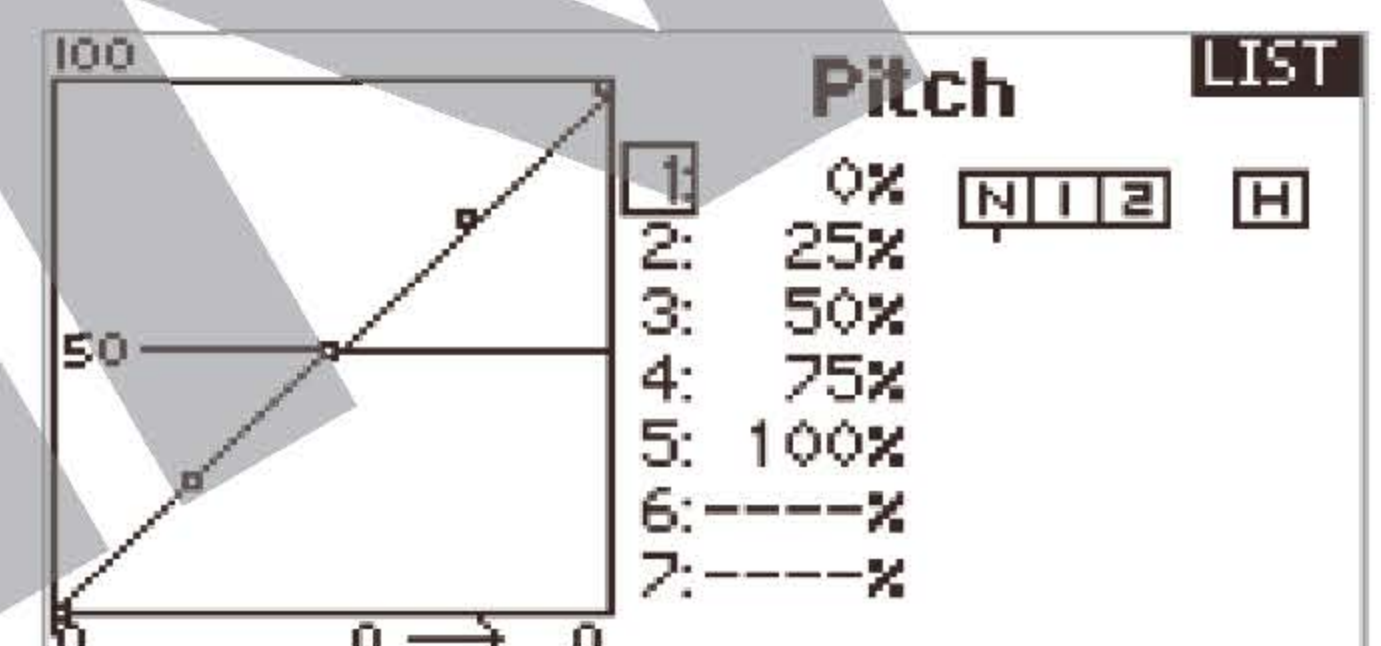
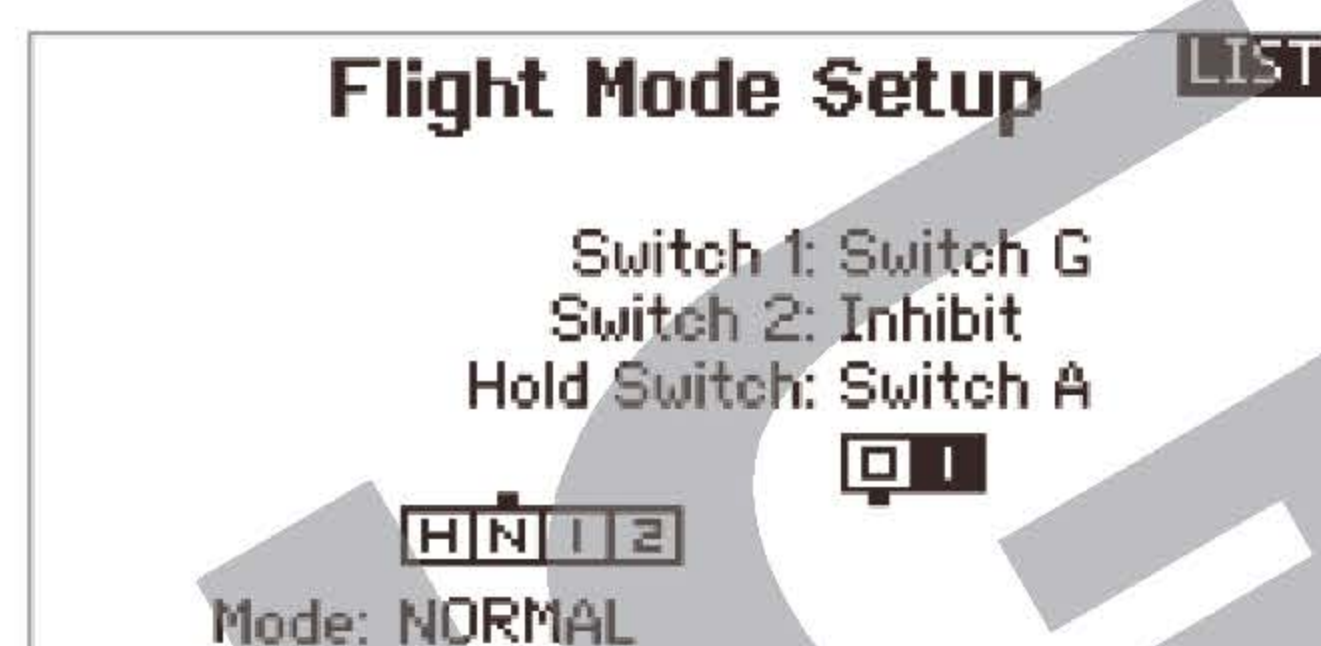
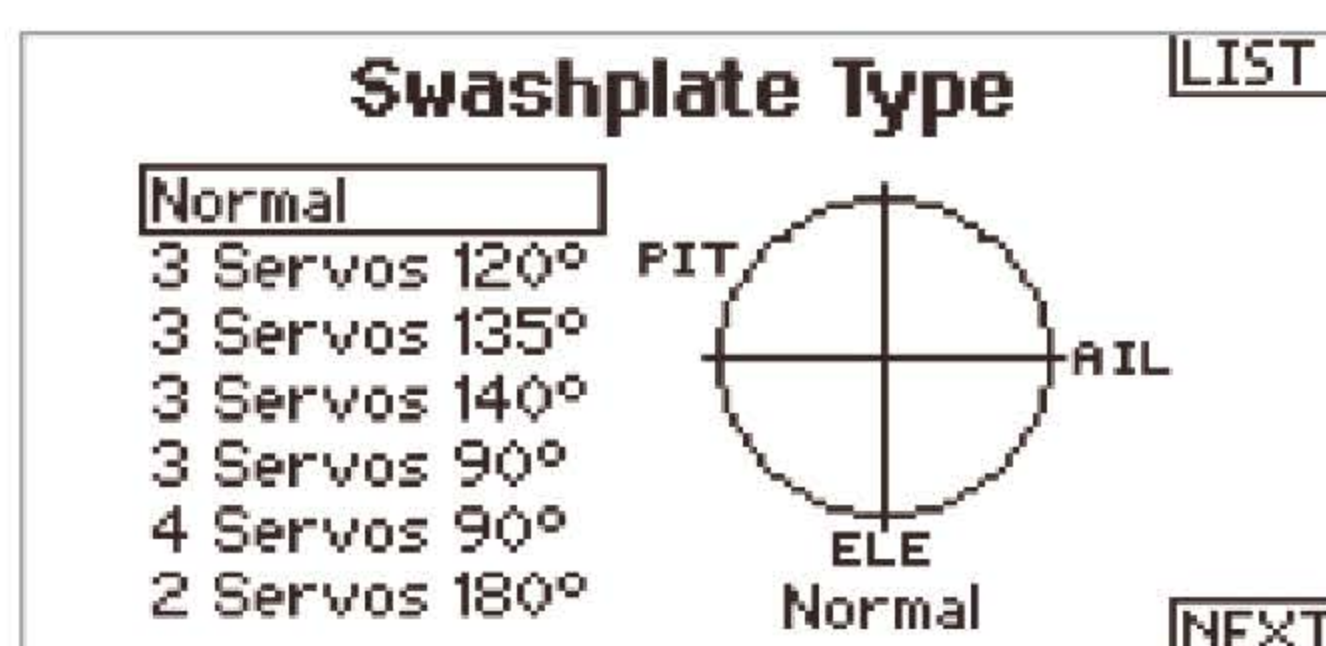

Each control function must exactly control one output channel. The servo throws must be set to 100% and all trims and sub trims must be zero. For the basic setup do not change the pitch curves yet. The throttle curves and throttle servo settings can be adjusted as necessary for this model in case you do not intend to use the internal RPM Governor function of MICROBEAST PLUS. If you want to use the integrated RPM Governor function also do not touch the throttle settings yet.

每個輸出通道必須精確對應到一個控制功能。伺服輸出必須設置為100%，所有微調和輔助微調必須為零。基本設定並不會改變螺距曲線。油門曲線和油門伺服的設定，可以根據需要來調整，如果您想使用傳統定速器來取代 MICROBEAST PLUS 內建的 RPM 定速模式，也請您先不要改變油門設定。

Only the pitch channel must be controlled when moving the thrust stick. The same applies to aileron, elevator and rudder.

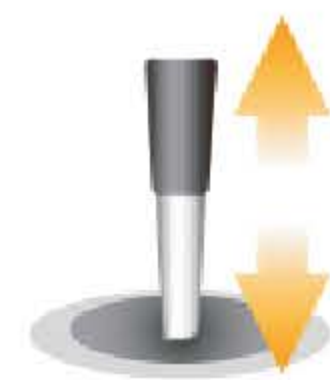

移動螺距搖桿時，只需控制螺距通道。同樣應用於副翼、升降及尾舵。

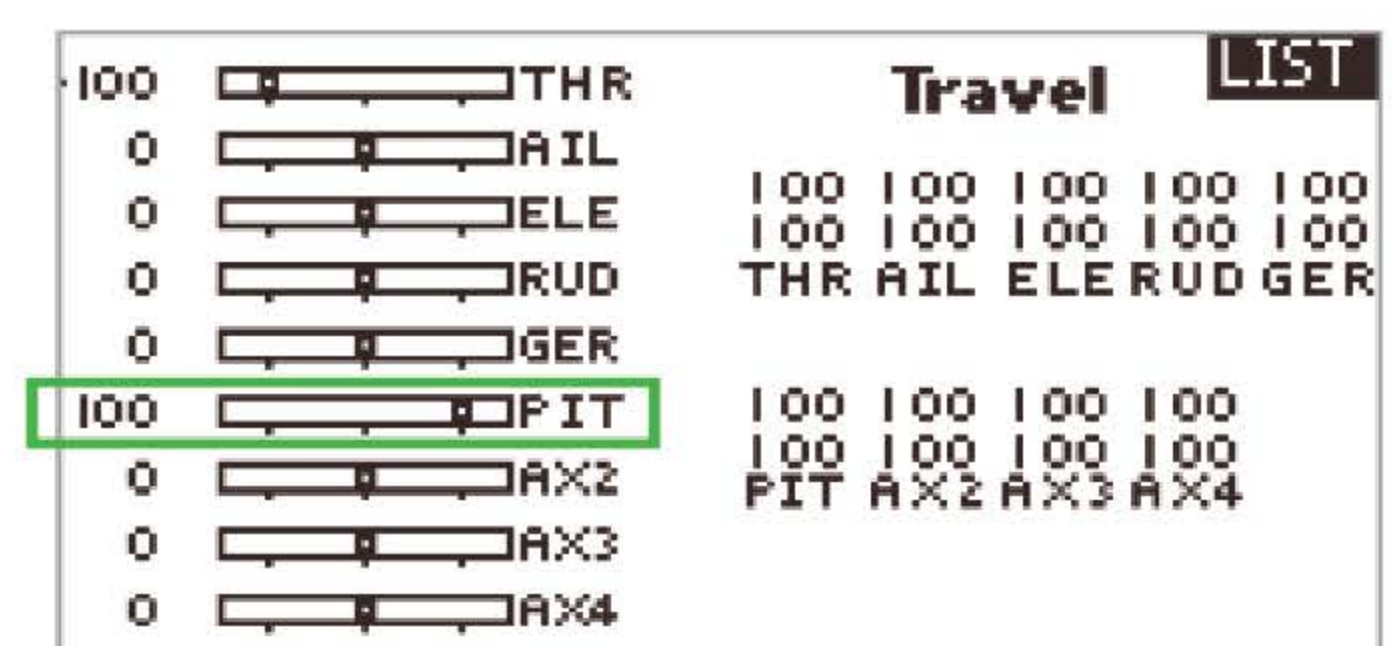
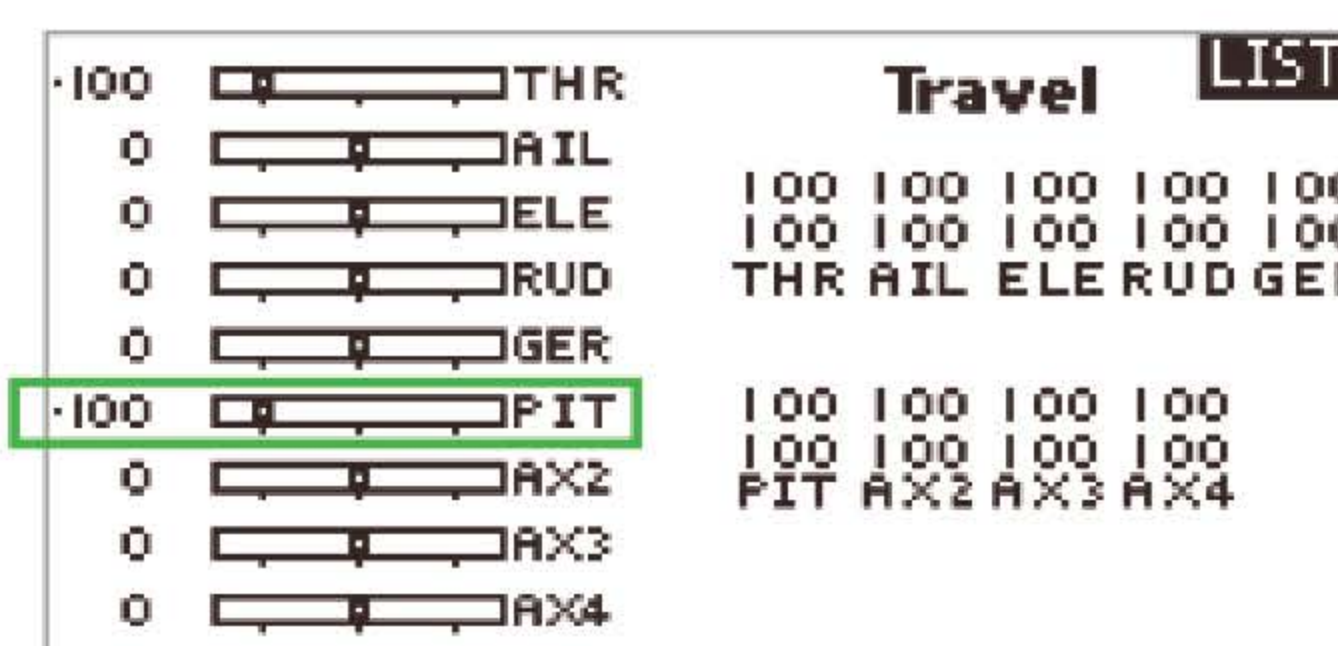

CAUTION 注意

With electric driven models remove the motor from the main gear when performing the basic setup for safety reason! Additionally deactivate the throttle by using the "Throttle HOLD" switch, so the motor won't start to turn when moving the thrust stick.

When flying a nitro or gasser heli remove the servo horn from the throttle servo before first power up to prevent jamming of the servo due to wrong servo setup.

基於安全理由，電動直升機在初始設定時，請移除主齒輪上的馬達驅動齒輪，以策安全！此外，請使用遙控器上的「Throttle HOLD」開關，來關閉油門，以確保在移動油門搖桿時馬達不會轉動。

飛行引擎直昇機，在第一次點燃引擎前，請先將油門伺服器臂移除，以免不小心或錯誤的設定而發動引擎，造成危險。

5 RECEIVER SETUP

接收器設定

ALIGN

To enter Receiver menu MICROBEAST PLUS must be switched off completely. Push and hold the button before and while powering on. Menu LED A will start to flash instantly.

At menu point A choose which type of receiver/transmission protocol is used. The color and state of the Status LED indicates which type is currently selected. By repeatedly pressing and holding the button you can switch between the receiver types. Briefly pushing the button will skip to menu point B or to the menu end in case you selected the "Standard" type.

在進入接收器選單前，必須將 MICROBEAST PLUS 完全關閉。進入接收器選單時，請長按按鈕，此時設定選單第 A 點旁的 LED 燈會立即閃爍。

在設定選單第 A 點，有「接收器類型」、「傳輸協議」的選項。LED 狀態指示燈的顏色表示當前的選擇。透過重複壓按幾次按鈕，您可以切換接收器類型。簡而言之，短按按鈕將略過此選項，直接到選單第 B 點，如果您使用的是「傳統接收器」請點選第 A 點最後的選項。

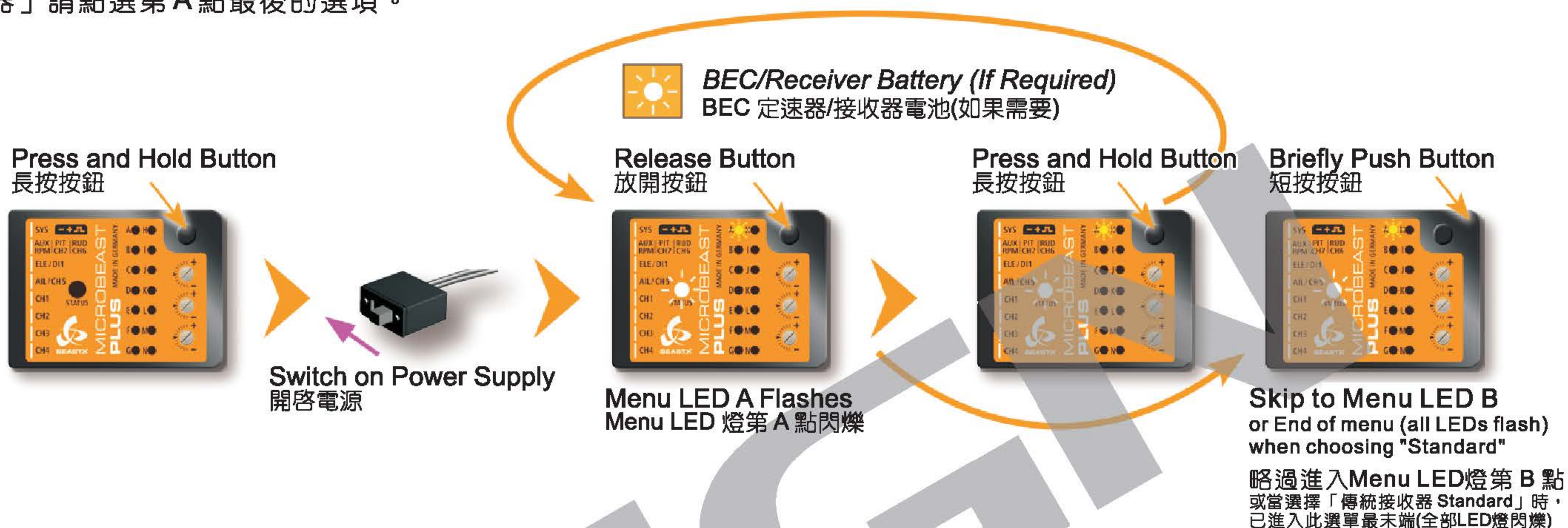

Status-LED Status-LED 燈	Off 熄滅	Flashing Purple 紫燈閃爍	Purple 紫燈	Flashing Red 紅燈閃爍	Red 紅燈	Flashing Blue 藍燈閃爍
A Receiver Type A 接收器類型	Standard 傳統	JR RJ01 Satellite	Spektrum Satellite	S-Bus	SRXL	SPPM

Single-Line receiver (Status LED not Off)

If the correct receiver type has been selected and transmitter and receiver are bound and switched on and if the receiver is sending a valid signal on the Single-Line output, the Status LED must light up in blue color at menu point B. Again press and hold the button here to load the default function assignment that has been preset for the selected radio system (see next page).

Alternatively you may program a different function assignment manually in case the default assignment does not work with your transmitter's function layout. How this works in detail you can read from the instruction manual which you can get from wiki.beastx.com.

單線連接接收器 (Status LED 燈不熄滅)

如果已經選擇了正確的接收器類型，且遙控器和接收器也對頻成功，接著開啓電源，如果接收器所輸出的訊號是有效的，此時，在選單第 B 點 Status-LED 燈必須亮起藍燈，請長按按鈕載入系統所預設之遙控器通道分配功能(請參閱下頁說明)。

此外，如果系統預設的通道分配功能不符合您遙控器的需求，您也可以用手動的方式來分配遙控器通道之功能。更多的詳情，請參閱說明書，或瀏覽 wiki.beastx.com。

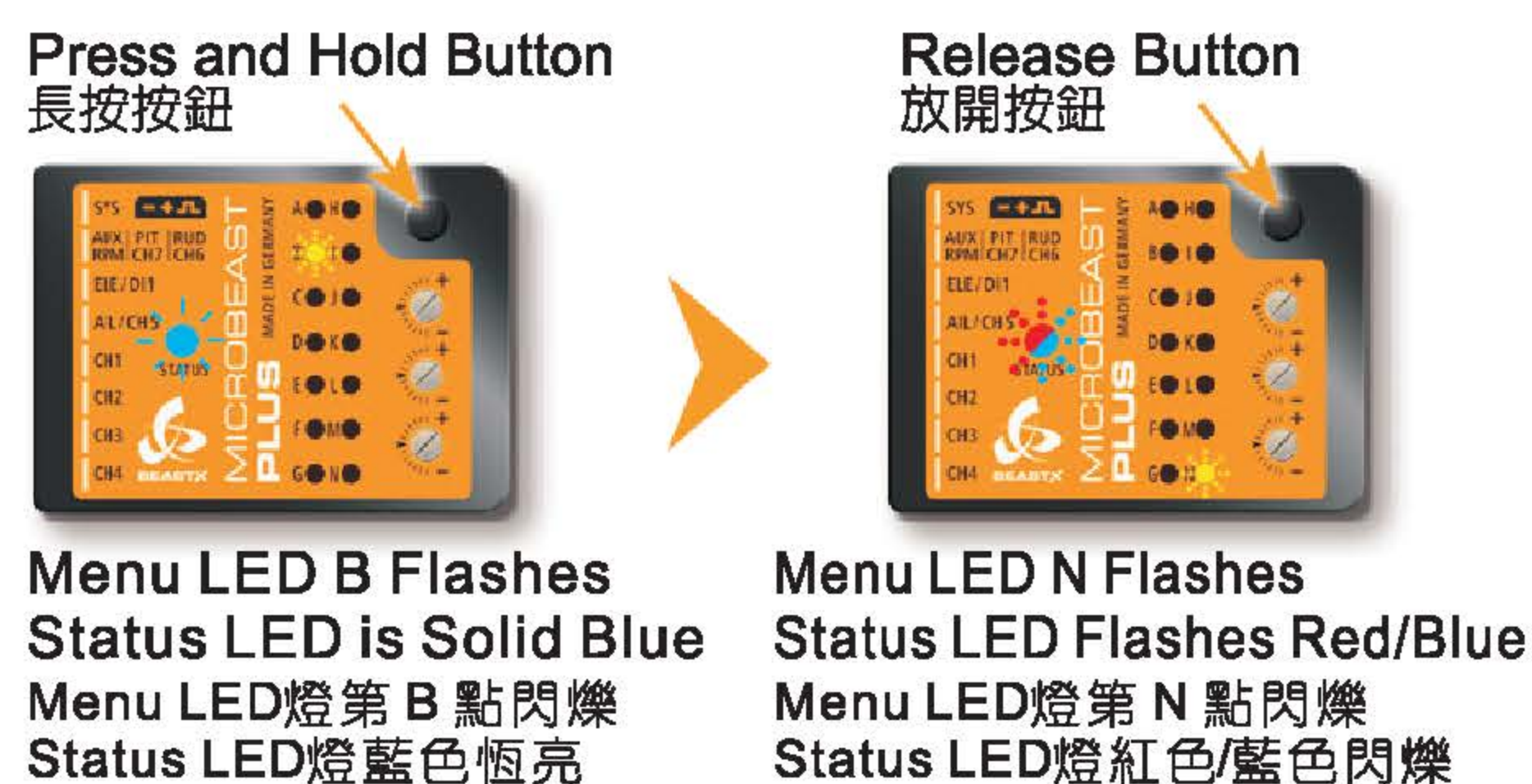

WARNING 警告

Warning! At menu point N (Throttle failsafe position) the throttle output CH5 is activated! Move the throttle to the desired failsafe position which will be set in case the Single-Line connection is interrupted oder gets disconnected.

Briefly push the button to save all the receiver settings now. Then the end of menu is reached which is indicated by all menu LEDs flashing.

警告！在選單第 N 點 (油門失控保護位置)，通道 5 [CH5] 油門輸出已經被開啓！請將油門搖桿移到您理想的位置，這裡就是油門失控保護的位置，如果使用的是單線連接方式，這裡就是中斷油門指令的位置。

現在，請短按一下按鈕以保存所有接收器的設定。接著就進入接收器選單最末端，此時，系統會以 LED 燈全部閃爍來表示。

	JR RJ01satellite	Spektrum Satellite	Futaba S-BUS	PPM composite signal* 複合信號
Channel* 通道	Function 功能	Function 功能	Function 功能	Function 功能
Channel 1 通道 1	Throttle [CH5] 油門 [CH5]	Aileron 副翼	Pitch 螺距	Pitch 螺距
Channel 2 通道 2	Aileron 副翼	Elevator 升降舵	Aileron 副翼	Aileron 副翼
Channel 3 通道 3	Elevator 升降舵	Throttle [CH5] 油門 [CH5]	Elevator 升降舵	Elevator 升降舵
Channel 4 通道 4	Rudder 尾舵	Rudder 尾舵	Rudder 尾舵	Rudder 尾舵
Channel 5 通道 5	Gyro Gain 感度	Gyro Gain 感度	AttitudeControl 姿態模式	AttitudeControl 姿態模式
Channel 6 通道 6	Pitch 螺距	Pitch 螺距	Throttle [CH5] 油門 [CH5]	Throttle [CH5] 油門 [CH5]
Channel 7 通道 7	AttitudeControl 姿態模式	AttitudeControl 姿態模式	Gyro Gain 感度	Gyro Gain 感度
Channel 8 通道 8	RPM Governor*** RPM定速模式***	RPM Governor*** RPM定速模式***	RPM Governor*** RPM定速模式***	RPM Governor*** RPM定速模式***
Channel 9 通道 9	Auxiliary [CH6] 輔助通道 [CH6]	Auxiliary [CH6] 輔助通道 [CH6]	Auxiliary [CH6] 輔助通道 [CH6]	Auxiliary [CH6] 輔助通道 [CH6]

SRXL				
	BEASTRX	Multiplex SRXL JR X .Bus Mode B JETI UDI	Graupner SUND	Spektrum SRXL
Channel* 通道	Function 功能	Function 功能	Function 功能	Function 功能
Channel 1 通道 1	Aileron 副翼	Aileron 副翼	Pitch 螺距	Throttle [CH5] 油門 [CH5]
Channel 2 通道 2	Elevator 升降舵	Elevator 升降舵	Aileron 副翼	Aileron 副翼
Channel 3 通道 3	Throttle [CH5] 油門 [CH5]	Rudder 尾舵	Elevator 升降舵	Elevator 升降舵
Channel 4 通道 4	Rudder 尾舵	Pitch 螺距	Rudder 尾舵	Rudder 尾舵
Channel 5 通道 5	Gyro Gain 感度	Throttle [CH5] 油門 [CH5]	AttitudeControl 姿態模式	Gyro Gain 感度
Channel 6 通道 6	Pitch 螺距	Gyro Gain 感度	Throttle [CH5] 油門 [CH5]	Pitch 螺距
Channel 7 通道 7	AttitudeControl 姿態模式	AttitudeControl 姿態模式	Gyro Gain 感度	AttitudeControl 姿態模式
Channel 8 通道 8	RPM Governor*** RPM定速模式***	RPM Governor*** RPM定速模式***	RPM Governor*** RPM定速模式***	RPM Governor*** RPM定速模式***
Channel 9 通道 9	Auxiliary [CH6] 輔助通道 [CH6]	Auxiliary [CH6] 輔助通道 [CH6]	Auxiliary [CH6] 輔助通道 [CH6]	Auxiliary [CH6] 輔助通道 [CH6]

When using SRXL the preset channel assignment is based on the receiver's protocol version. MICROBEAST PLUS will detect automatically which brand of receiver is used and will choose the appropriate channel assignment accordingly.

* Channel designation of Spektrum transmitters: THR, AIL, ELE, RUD, GER, PIT, AX2, AX3, AX4

** only applicable with ProEdition firmware otherwise this channel by default controls CH6 Auxiliary output instead of channel 9

*** only for models with nitro or gas engine

When using a receiver with "Standard" 5-wire layout the function assignment is simply determined by the order of physical connection of the wires to the receiver outputs. Assignment by software is not provided and will not appear when choosing this type of receiver. Here the AttitudeControl function (optional) will be controlled using the tail gyro gain channel. The RPM Governor function can't be used in combination with this type of receiver. After choosing "Standard" (Status LED off) at menu point A and briefly pushing the button receiver setup is finished.

SRXL 預設通道是根據接收器的溝通協議版本來分配的。MICROBEAST PLUS 會自動檢測不同品牌的接收器來選擇合適的通道分配。

*Spektrum 遙控器通道分配：THR、AIL、ELE、RUD、GER、PIT、AX2、AX3、AX4

**此版本僅適用於 ProEdition 主程式，請注意原廠將 [CH6] 預設為輔助通道，而不是通道 9 [CH9]。

***僅適用於引擎直昇機

若使用「傳統接收器」，遙控器的通道分配只能有 5 個功能，且只能利用接收器連接線的物理順序來決定通道功能。如果您選擇使用傳統接收器，系統所提供的通道分配功能和接收機類型將不會出現。在這裡，雖然可選取姿態模式，但系統僅提供尾舵螺儀功能。請注意，RPM 定速模式不支援傳統接收器。在選單第 A 點選擇 "Standard" 後，此時 Status LED 燈將會熄滅，接著短按按鈕，接收器的設定就完成了。

6 SETUP MENU

設定選單

ALIGN



Switch on Transmitter
開啓遙控器



Switch on Power Supply
開啓電源供應



Self Test
自行測試



Status LED Lights Up
Red→Blue→Purple
Status LED 燈亮起
紅色→藍色→紫色

Firmware version: 4.1.x
主程式 V 4 .1 .x:



Calibration of
Radio Channels
遙控器通道校正



Do not move sticks
on the radio!
請勿移動遙控器搖桿

Calibration of sensor
rest positions
感應器位置校正



Do not move
the helicopter!
請勿移動直昇機

Operation Mode
操作模式



Status LED Lights Up
Blue or Purple
Status LED 燈亮起
藍色或紫色

Entering Setup Menu 進入設定選單

Press and Hold Button
長按按鈕

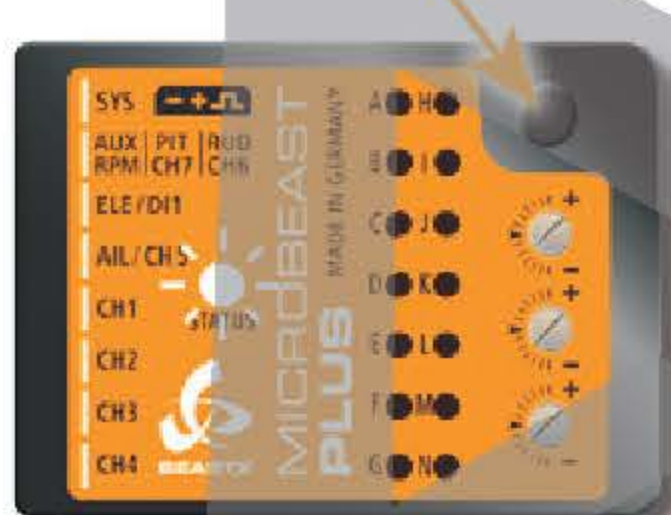

Operation Mode
(Status LED is Blue or Purple)
操作模式
(Status LED 燈藍色或紫色)

Keep Button Pressed Down
持續按著按鈕

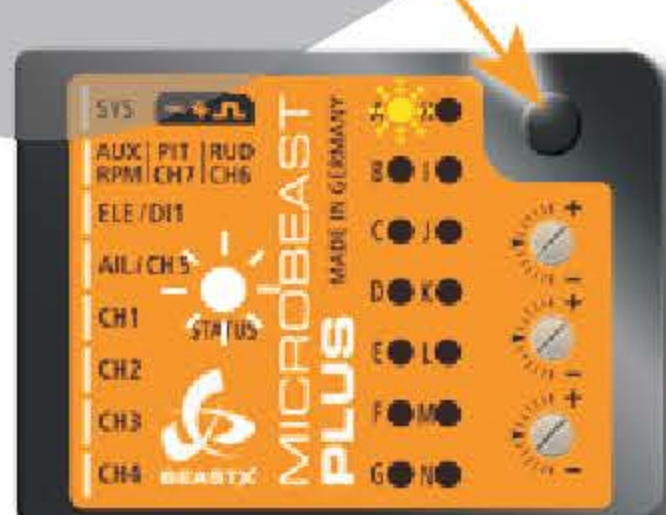

Menu LED A Flashes
設定選單 LED 燈第 A 點閃爍

Release Button
放開按鈕



Menu LED A lights up solid
(= Setup menu point A)
設定選單 LED 燈第 A 點恆亮
(=設定選單第 A 點)

SETUP MENU POINT A - DEVICE ORIENTATION (MENU LED A SOLID LIT UP) 設定選單第 A 點-放置方位(設定選單 LED 燈第 A 點恆亮)

Check the selected device orientation and change it if necessary by (repeatedly) moving the rudder stick into one direction until the Status LED color corresponds to the real device orientation. Then briefly push the button to save the setting and to proceed to the next menu point.

請檢查 MICROBEAST 所放置的方位是否正確，您可以將尾舵搖桿重複往一個方向移動，直到 Status-LED 燈號對應到 MICROBEAST 的方位為止。然後短按按鈕保存設定，並進入下一個選單點。

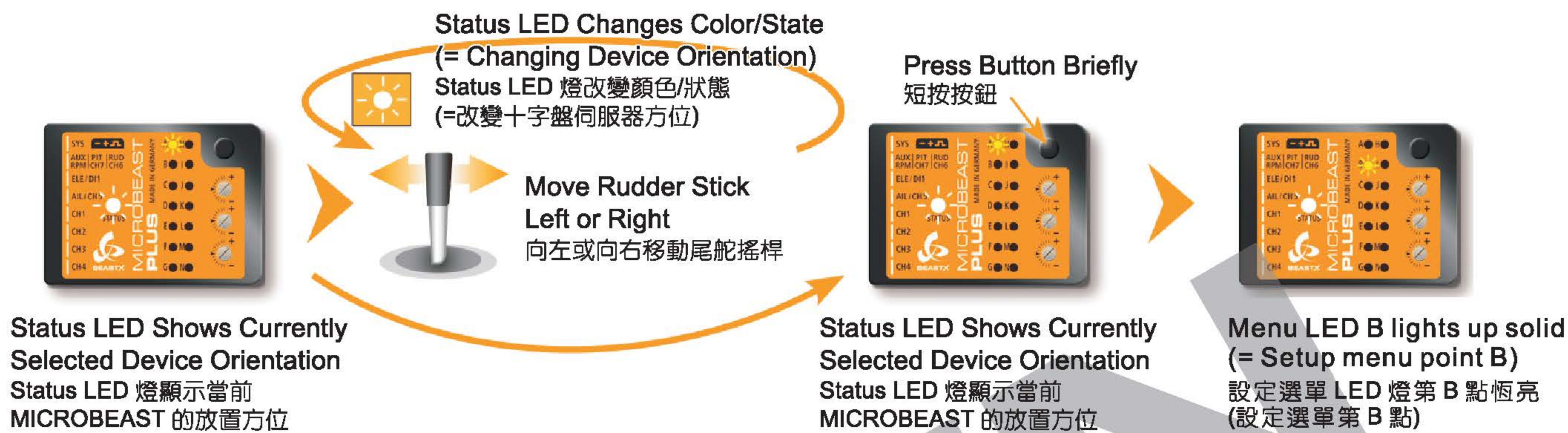

SETUP MENU POINTS B, C AND D

設定選單第 B、C、D 點

The currently selected swashplate servo update rate (B), rudder servo update rate (D) and rudder servo center pulse (C) are indicated by the color and state of the Status LED at each menu point. By moving the rudder stick to one or another direction you can change between the available options (if necessary). Briefly pressing the button will save the selected option and move to the next menu point.

當前十字盤伺服器的更新速率(B)，尾舵更新速率(D)和尾舵中心脈寬(C)，會由每個選單點旁的狀態指示燈的顏色來表示。請左右移動尾舵搖桿到一個方向，接著根據下表來選擇符合的燈號，然後短按按鈕，儲存您的選項，並移動到下一個選單點。



Status-LED Status-LED燈	Off 熄滅	Purple 紫燈	Flashing Red 紅燈閃爍	Red 紅燈	Flashing Blue 藍燈閃爍	Blue 藍燈
B Swashplate Servo B 十字盤伺服器	User Defined 使用者自訂義	50 Hz*	65 Hz	120 Hz	120 Hz	200 Hz
C Rudder Servo Center Pulse C 尾舵伺服器中立點訊頻寬	User Defined 使用者自訂義	960 μ s	—	760 μ s	—	1520 μ s
D Rudder Servo Update Rate D 尾舵伺服器更新速率	User Defined 使用者自訂義	50 Hz*	120 Hz	270 Hz	333 Hz	560 Hz

CAUTION 注意

If you don't know what the maximum update rate that is tolerated by your servos never use more than 50Hz. The higher the update rate the better it is for the flight performance of MICROBEAST PLUS but you must check the servo specifications before increasing the update rate. Otherwise the servos may get damaged! See WIKI.BEASTX.COM for a list with parameter examples for most servo types commonly used in flybarless helicopters.

如果您不知道您伺服器的最大更新速率，請勿設定超過 50Hz，此為伺服器的最大極限。較高的更新速率能讓 MICROBEAST PLUS 有較好的飛行表現，但您必須先檢查所使用伺服器的規格是否符合系統要求。否則，錯誤的選擇會導致伺服器損壞！請瀏覽 WIKI.BEASTX.COM 查看更多符合無平衡翼直昇機常用的伺服器類型與參數表。

SETUP MENU POINT E - RUDDER SERVO LIMIT

設定選單第 E 點-尾舵伺服器極限

Plug the rudder servo connector into CH4 output of MICROBEAST PLUS. Put the servo arm on the servo so that it forms roughly an angle of 90 degrees with the rudder linkage rod and adjust the length of the linkage rod as described in the helicopter manual.

請將尾舵伺服器連接線插入 MICROBEAST PLUS 的 [CH4] 輸出通道，接著裝上伺服器臂，使其大約和尾舵連桿成 90 度垂直，並請依直昇機說明書來調整連桿頭的長度。

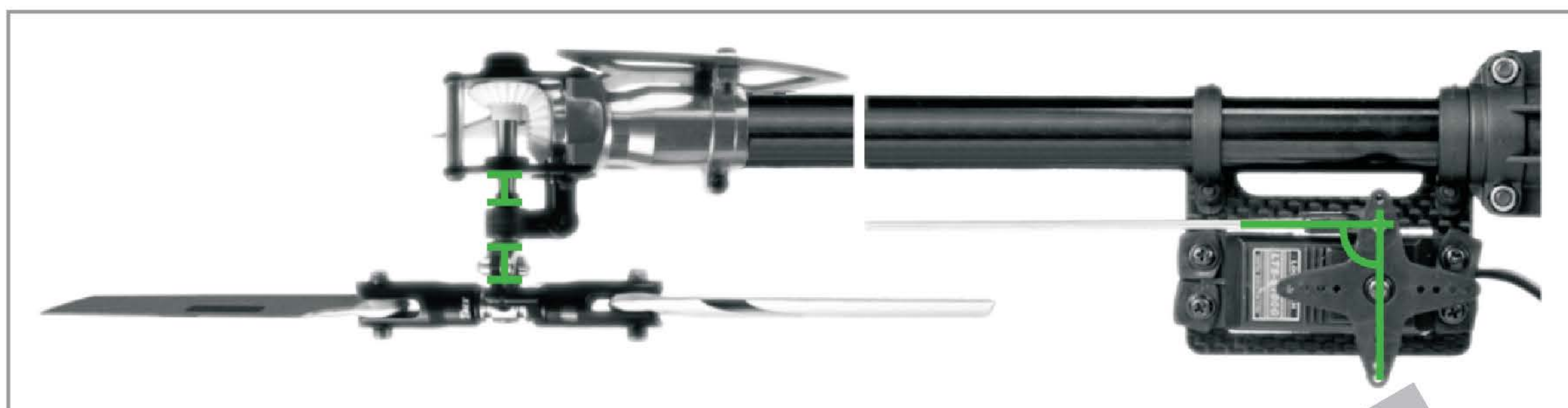

Push and hold the rudder stick into one direction to move the rudder servo and release the stick when the servo reaches the maximum or minimum allowed servo throw. Using the rudder stick you can reposition the servo at any time to adjust the exact servo limit. If you do not touch the rudder stick for several seconds the current servo position will be saved as maximum or minimum (the Status LED will flash and then light up solid in blue or red color). Then move the servo to the opposite direction and wait until also this position gets stored (Status LED becomes purple).

握住尾舵搖桿往左或右一邊方向移動，然後放開搖桿，使尾舵伺服器的行程量達到最大或最小。您可以利用尾舵搖桿隨時調整伺服器極限行程的精確位置。如果放開尾舵搖桿幾秒鐘，當前位置將被設定為最大或最小行程量，此時，Status-LED 燈會閃爍，然後恆亮為藍色或紅色。同樣，移動搖桿往反向設定，等待燈號恆亮為紫色並儲存即可。



Menu LED E Solid
Status LED Off
設定選單 LED 燈第 E 點恆亮
且 Status-LED 燈熄滅



Use rudder stick to move the servo to Release rudder stick the maximum allowed deflection
利用尾舵搖桿來移動伺服器，使其達到尾舵的最大容許偏轉率。

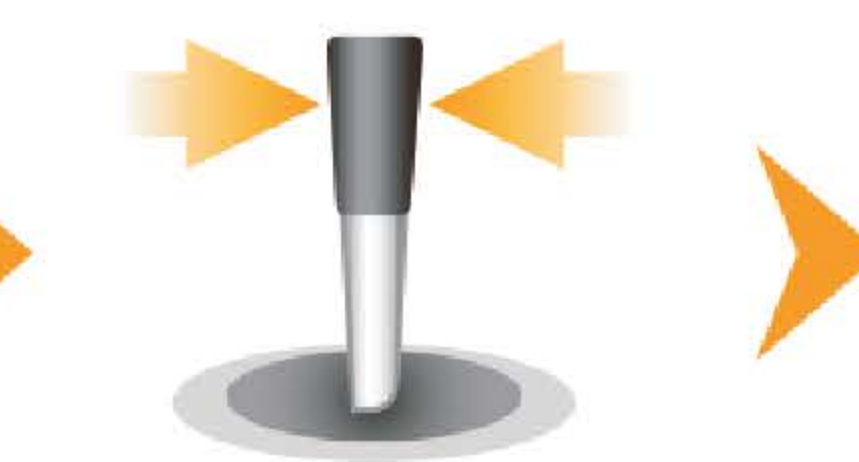

Release Rudder Stick
放開尾舵搖桿



Status LED Blue or Red
Status-LED 燈藍色或紅色



Use rudder stick to move the servo to the minimum allowed deflection
移動尾舵搖桿來調整伺服器至最小偏轉率。

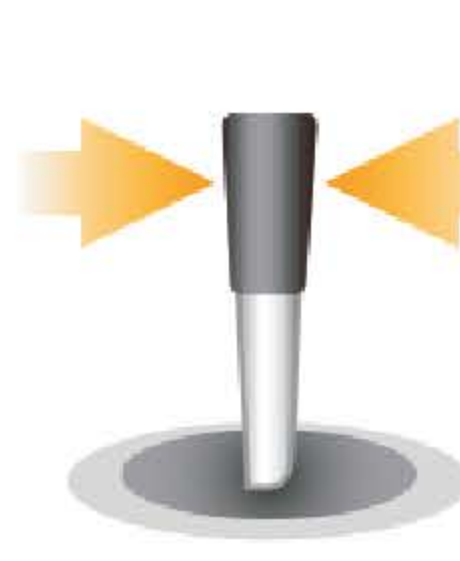

Release Rudder Stick
放開尾舵搖桿

Press Button Briefly
短按按鈕



Status LED Purple
Status-LED 燈紫色



Menu LED F Solid
(= Menu Point F)
設定選單 LED 燈第 F 點恆亮
(= 設定選單第 F 點)

When moving the rudder stick check if the servo is moved into the correct direction so that the helicopter will be moved correctly in flight. If this is not the case use the servo reverse function of your transmitter and reverse the channel output that controls the rudder function.

移動尾舵搖桿來檢查尾舵伺服器移動的方向是否正確，這樣直昇機在飛行時移動的方向才會正確。如果方向不正確，請利用遙控器的反向功能來調整即可。

SETUP MENU POINT F - TAIL GYRO DIRECTION

設定選單第 F 點-尾陀螺儀方向

Lift the helicopter at the rotorhead and turn it on the vertical axis by hand. Observe in which direction the rudder servo moves the tail rotor when turning the heli. The tail rotor must produce thrust against the direction of movement so that the rotation will be stopped by the gyro in flight. For example if you move the helicopter's nose to the left the gyro must steer to the right similar as you would move the rudder stick to the right manually.

用手舉起直昇機往垂直方向上下擺動，然後觀察主旋翼在旋轉時，尾舵伺服器的旋轉方向是否正確。尾旋翼轉動的方向必須產生阻力以抵銷推力，MICROBEST PLUS 會在飛行時介入尾旋翼的控制。例如，如果您將直昇機的機頭向左移動，陀螺儀必須向右修正，就如同您用手打尾舵向右的情形是一樣的道理。

Wrong
錯誤

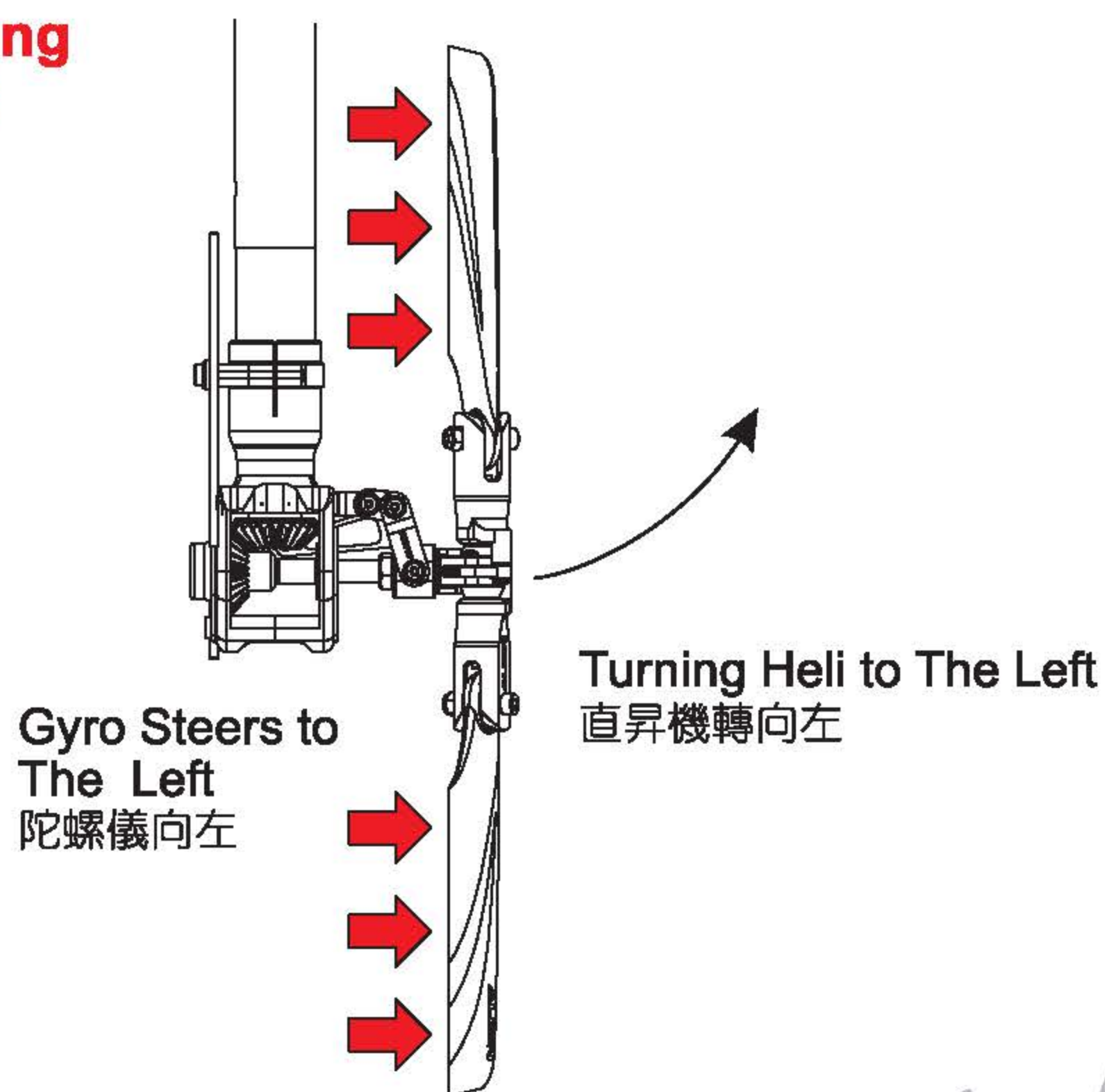

Correct
正確

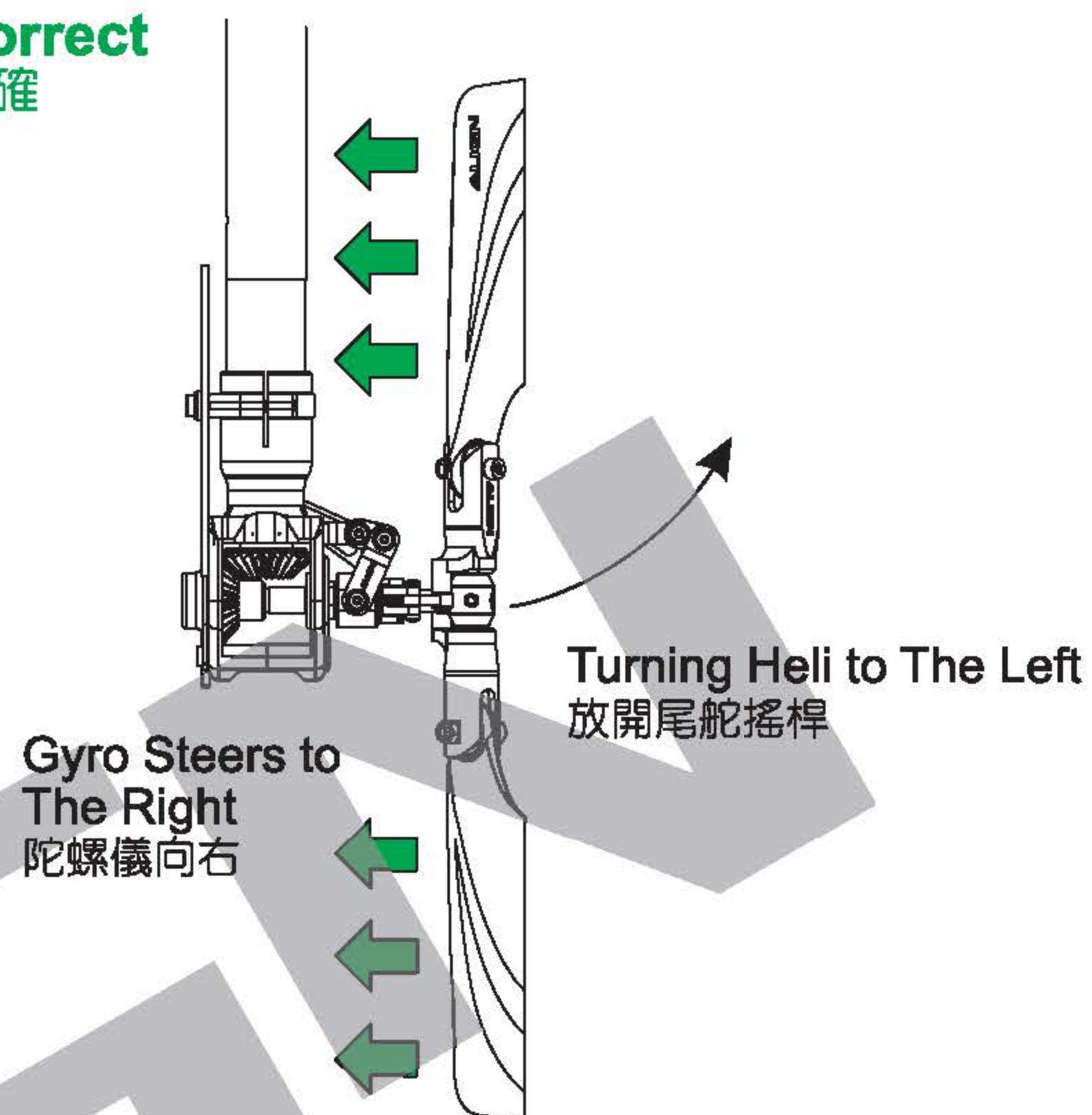

Note: These pictures are only exemplary. Check your helicopter's manual to find out which direction your tail rotor has to move.

If necessary reverse the tail gyro direction by briefly pushing the rudder stick into one direction at menu point F (Status LED color will change). Then briefly push the button to proceed with setting up menu point G.

請注意：這些圖片僅供參考。請參考您的直昇機說明書來確定尾旋翼移動方向。

如有必要將尾陀螺儀反向，請在設定選單第 F 點將尾舵搖桿往一個方向移動，接著短按按鈕，此時 Status-LED 燈號會改變，然後再一次短按按鈕，進入設定選單第 G 點來反向尾陀螺儀。

SETUP MENU POINT G - SWASHPLATE SERVO TRIM

設定選單第 G 點-十字盤伺服器微調

Plug all three swashplate servos to the outputs marked with CH1 to CH3 in the order as shown below. Then put the servo arms on the servos so that they form roughly an angle of 90 degrees with the linkage rods.

如下圖所示，請將三個十字盤伺服器依照 [CH1] 到 [CH3] 的輸出位置裝上連桿頭。然後再將伺服臂連接到伺服器，使它們大約和伺服連桿成 90度垂直。

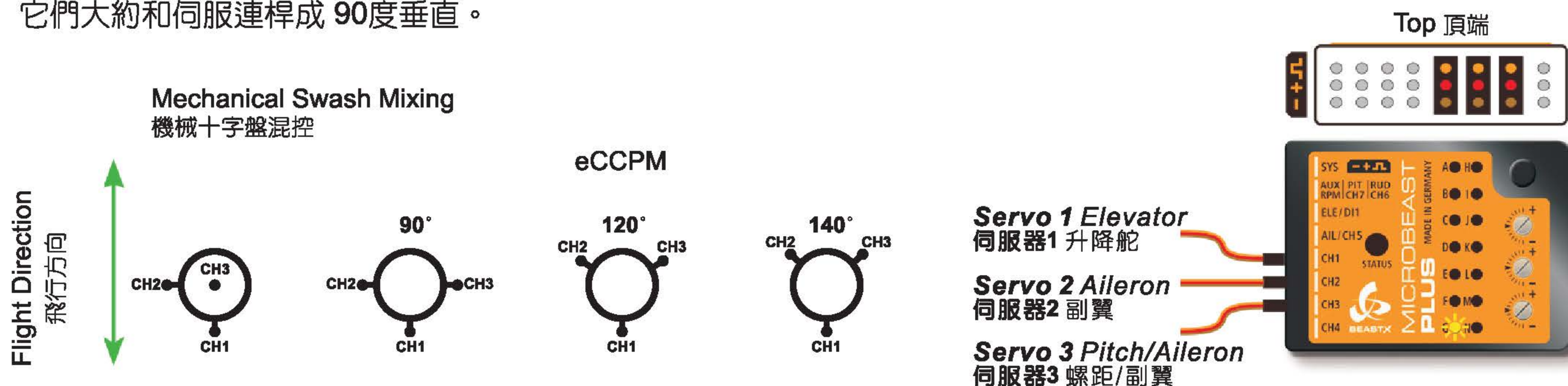

By moving the rudder stick into one direction repeatedly select one servo after another and adjust each servo's center position by moving the elevator stick forwards or backwards so that the servo arm is positioned exactly 90 degrees to the linkage rod. The servo number that is currently selected and that can be trimmed at the moment is indicated by the Status LED color.

您可以將尾舵搖桿往一個方向重複移動，來調整每個伺服的中心點，將升降搖桿向後或向前重複移動，使伺服臂和伺服器連桿精確地定位於 90 度的位置。目前所顯示的伺服器編號是可以調整的，請依照 Status-LED 燈的顏色來調整編號。

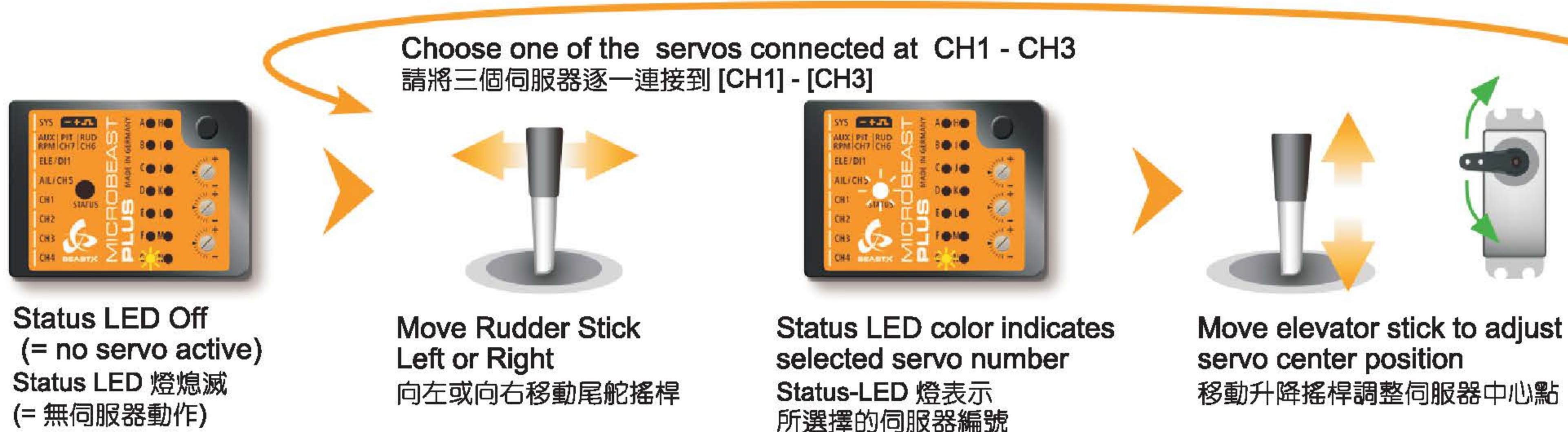

CAUTION
注意

Check all servo positions by selecting each servo once even when the servo arms are perfectly positioned when Status LED is off.

即使是伺服臂和伺服器連桿已經完全定位好，Status-LED 燈熄滅的情況下，也請您再一次檢查所有伺服器的位置是否正確。

When the servos are adjusted perfectly let one servo selected (only the electrical trim positions are important and are used in the further steps) and adjust the linkage rods going from servos to the swashplate and from the swashplate to the blade grips. The swashplate must be leveled and centered on the main shaft and the blade grips should be set to 0° pitch. Then briefly push the button to get to menu point H.

當伺服器調整完成時，請透過遙控器選擇其中一個伺服器來檢查它的連桿在十字盤和主旋翼夾座的移動是否順暢，請逐步仔細檢查，從伺服器到十字盤，再從十字盤到主旋翼夾座（電動微調伺服器的位置是很重要的，接下來會有很多地方用得到此步驟）。請注意，十字盤的位置必須置中垂直於主軸，主旋翼夾座的螺距必須為 0°。接著，短按按鈕進入設定選單第 H 點。

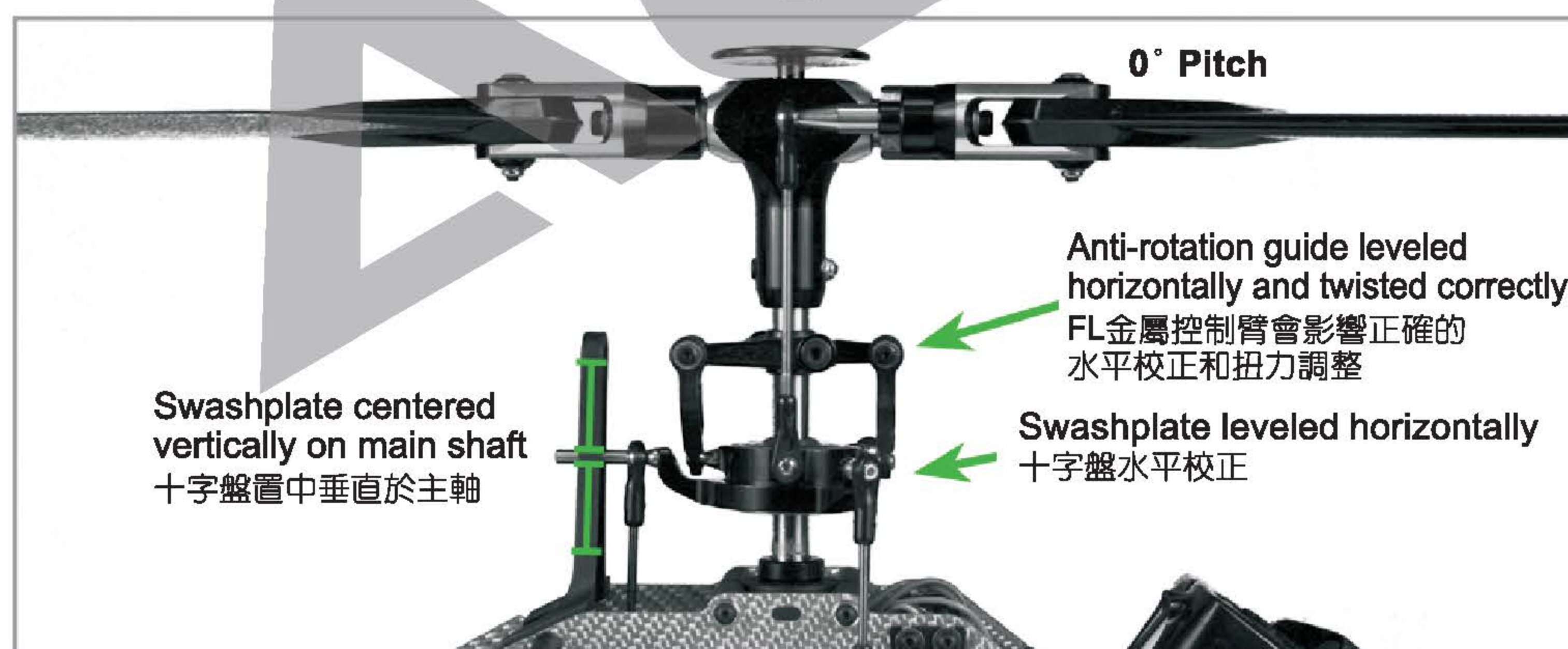

Linkage balls of swashplate outer ring and blade grips must be on one line

十字盤球頭外環與主旋翼連桿組必須在同一行。

If necessary adjust the swashplate anti-rotation guide so that there is no swashplate phasing (only applies to 2-blade rotorheads).

必要時可調整十字盤的 FL 金屬控制臂，使其無十字盤定相 (swashplate phasing) (僅適用於雙螺旋槳旋翼頭直昇機)。

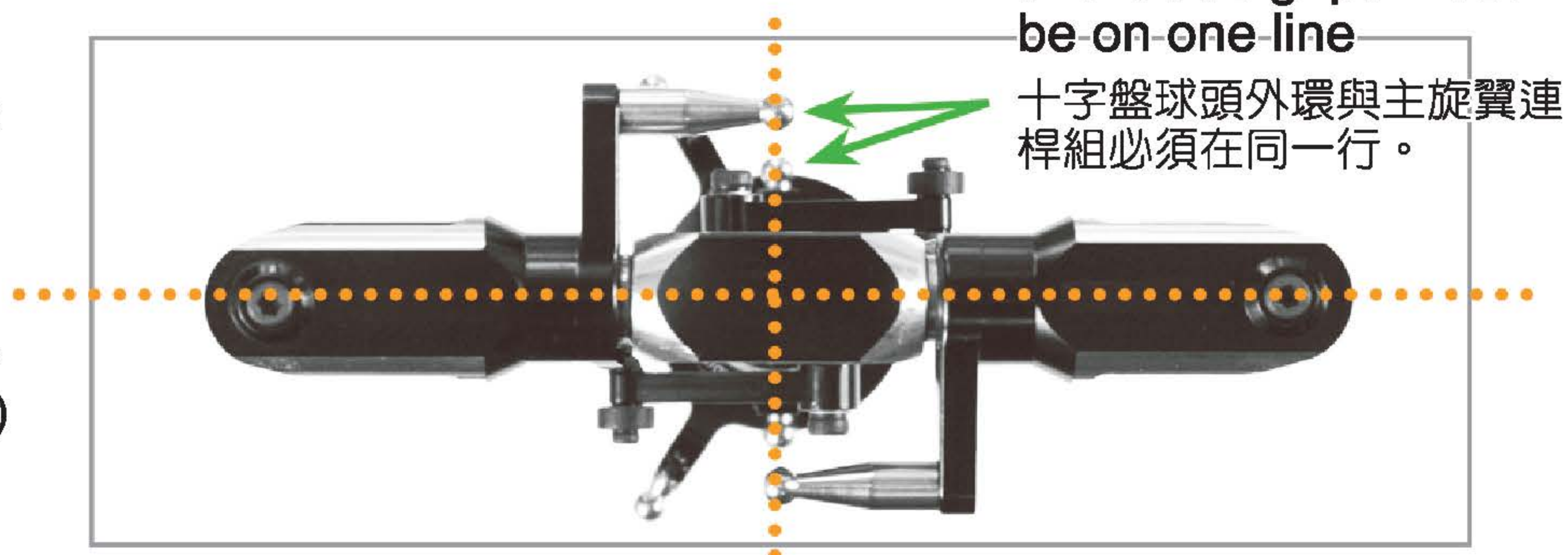

SETUP MENU POINT H - SWASHPLATE MIXING TYPE

設定選單第 H 點-十字盤混控類型



Status LED shows currently selected mixing type
Status-LED 燈顯示目前選擇的混控類型



Press Button Briefly
短按按鈕



Status LED shows currently selected mixing type
Status-LED 燈顯示目前選擇的混控類型

Status-LED Status-LED燈	Off 熄滅	Purple 紫燈	Flashing Red 紅燈閃爍	Red 紅燈	Flashing Blue 藍燈閃爍	Blue 藍燈
H Swashplate Mixing Type H 十字盤混控類型	User Defined 使用者自訂義	Mechanical 機械混控	90°	120°	140°	135°/140° (1:1)

SETUP MENU POINT I - SWASHPLATE SERVO DIRECTIONS

設定選單第 I 點-十字盤伺服器方向

Only move the thrust stick and check if all servos push the swashplate up and down simultaneously. If this is not the case move the rudder stick into one direction once to switch to the next servo configuration and try again. Repeat this until the servos move the swashplate correctly. There are four possible configurations and only one will be correct.

移動油門搖桿來檢查伺服器行程是否正確，請將十字盤向上或向下推動。如果動作不正確，請將尾舵搖桿往一個方向移動一次，接著切換到下一個伺服器組合，再嘗試一次。請重複這個步驟，直到伺服器能正確移動十字盤。有四種可能的伺服器組合，但只有一個是正確的。

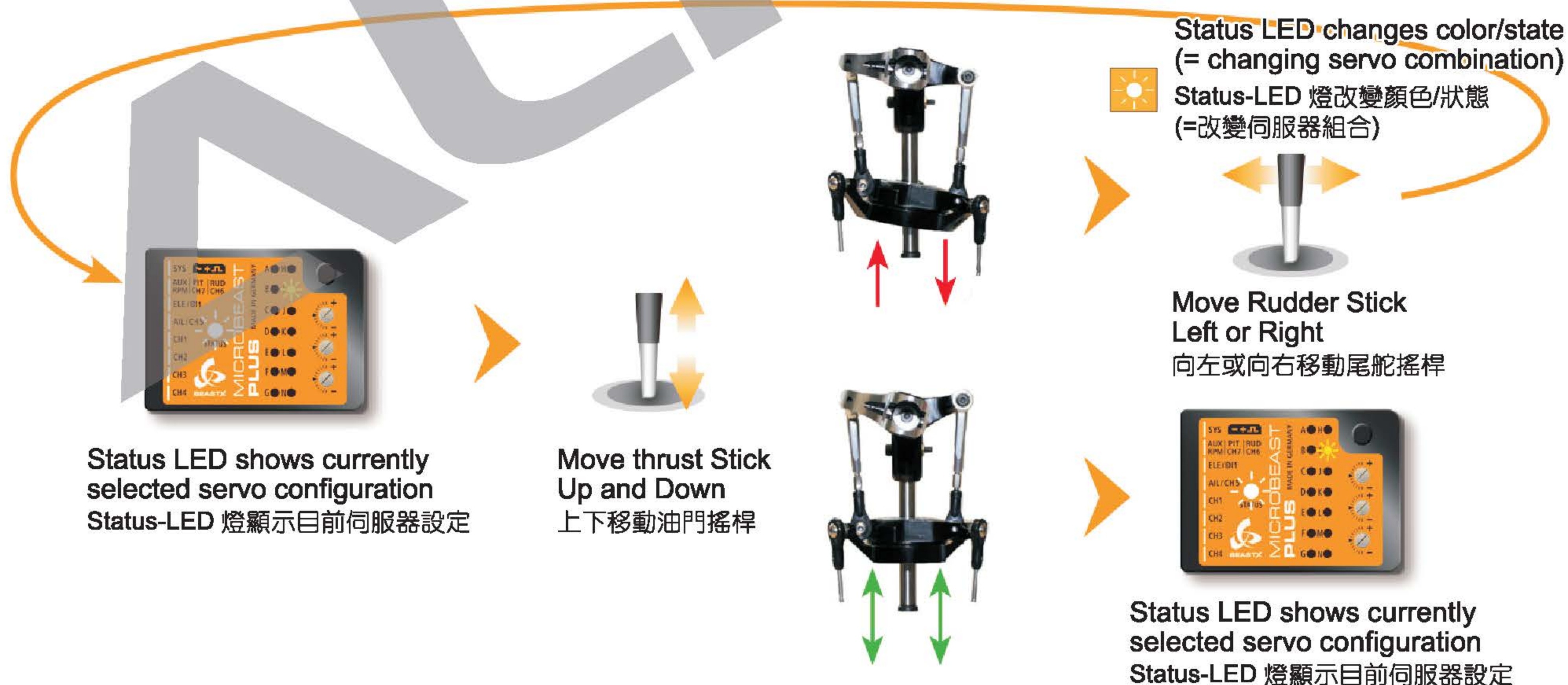

Now also check if the sticks are moving the swashplate in the correct directions. If one or more directions are wrong use the servo reverse function of your transmitter to reverse the channel output for the channel which controls the specific function. Do not use the servo reverse function of MICROBEAST PLUS to change stick directions!

When the swashplate can be controlled by the sticks correctly, briefly push the button to skip to menu point J.

接下來用油門搖桿檢查十字盤移動的方向是否正確。如果其中有一個或多個方向是錯誤的，請使用遙控器上的反向功能，來反向通道輸出。請勿使用 MICROBEAST PLUS 的伺服器反向功能來改變移動方向！

當搖桿可以正確的控制十字盤後，按一下按鈕跳到選單第 J 點。

SETUP MENU POINT J - SWASHPLATE SERVO THROW

設定選單第 J 點-十字盤伺服器行程量



Align rotorhead and rotorblades in parallel to the helicopter's longitudinal axis. Attach a pitch gauge/level meter to one of the rotor blades or to a blade grip in order to **measure aileron pitch**. Use your smartphone to scan QR Code or link to Align website for more complete instruction:

http://shop.align.com.tw/index.php?cPath=11_35_351&page=1&language=tw .

Align 直昇機的頭速和旋翼頭的設計是平行於直昇機的 X 軸，並且提供螺距規和十字盤校正器(另購品)，可以用來校正螺距，非常方便好用，請參考相關網頁。手機掃描 QR Code 將會有更完整的亞拓產品介紹。若手機無法掃描 QR Code 請上亞拓官網 http://shop.align.com.tw/index.php?cPath=11_35_351&page=1&language=tw 。

**Menu LED J Solid
Status Led Off
Menu-LED 燈第 J 點恆亮，
Status-LED 燈熄滅**

**Push and hold aileron stick into one direction of your choice just until exact +6 oder -6 degrees of pitch are reached
將副翼搖桿推往一個方向，直到螺距達到 +6 跟 -6 度。**

**Status LED Should Be Solid Blue
(See instruction manual for further details on the LED colors)
Status-LED燈需恆亮藍色
(參考說明書的 LED 燈號介紹)**

**Menu LED K Solid
(= Menu Point K)
設定選單第 K 點恆亮
(=選單第 K 點)**

Press Button Briefly
短按按鈕

SETUP MENU POINT K - COLLECTIVE PITCH

設定選單第 K 點-集體螺距

**Move thrust stick to maximum positive pitch and let it stay there
移動螺距搖桿到最大正螺距並停留。**

**Move aileron stick to adjust maximum positive collective pitch (i. e. +12°)
移動副翼搖桿調整最大正集體螺距(例如 +12°)**

**Status LED Red
Status-LED 燈紅色**

**Move Rudder Stick Left or Right
向左或向右移動尾舵搖桿**

**Status LED Gets Blue
Status-LED 燈藍色**

**Status LED must be blue when collective pitch is positive!
當集體螺距為正時，Status LED 燈必須亮藍色**

**Move thrust stick to full negative pitch and let it stay there
移動油門搖桿到最大負螺距並停留。**

**Move aileron stick to adjust maximum negative collective pitch (i. e. -12°)
移動副翼搖桿調整最大負集體螺距(例如 -12°)**

**Status LED red when collective pitch is negative!
當集體螺距為負時，Status-LED 燈亮紅色**

Press Button Briefly
短按按鈕

SETUP MENU POINT L - SWASHPLATE SERVO LIMIT

設定選單第 L 點-十字盤伺服器極限

You can remove the pitch gauge now! Simultaneously move the sticks for thrust, aileron and elevator to the maximum deflection and check if the servos, swashplate or linkages get jammed in a certain position. By pushing and holding the rudder stick left or right you can increase or decrease the limit for the servos! Adjust the limit so that the servos just don't get jammed in any possible stick position but don't limit the servos more than necessary.

現在，您可以移除螺距規！同時，請移動油門搖桿，副翼和升降舵到最大偏轉的位置，接著檢查螺距，十字盤或連桿是否會在某個位置卡卡的。利用向左或向右移動尾舵搖桿，您可以增加或減少伺服器行程！此調整是為了提高搖桿在控制伺服器時的順暢度，但也沒必要超過極限。



Menu LED L solid Status LED shows the amount of limiting
Menu-LED 燈第 L 點恆亮及 Status-LED 燈顯示極限總數



Move thrust, aileron and elevator sticks carefully to maximum deflection!
小心地移動螺距、副翼和升降搖桿到最大偏轉！

Move rudder stick to adjust the servo limit
移動尾舵搖桿調整伺服器極限



Press Button Briefly
短按按鈕

Status LED should be solid blue (See instruction manual for further details on the LED colors)
Status-LED 燈需恆亮藍色 (參考說明書的 LED 燈號介紹)

SETUP MENU POINT M - COLLECTIVE PITCH

設定選單第 M 點-集體螺距

Lift the helicopter at the rotor head and tilt it by hand forwards and sideways. Watch how the gyro is correcting the swashplate. **The system has to steer against the movement of the helicopter keeping the swashplate level.** If the swashplate tilts into the direction of movement you have to reverse the compensation direction for this axis.

舉起直昇機的旋翼頭，用手使其向前和向側邊傾斜。觀察陀螺儀修正十字盤是否正確。系統必須做出修正補償，讓直昇機的十字盤保持水平。如果十字盤往一邊傾斜，必須做出反向修正。

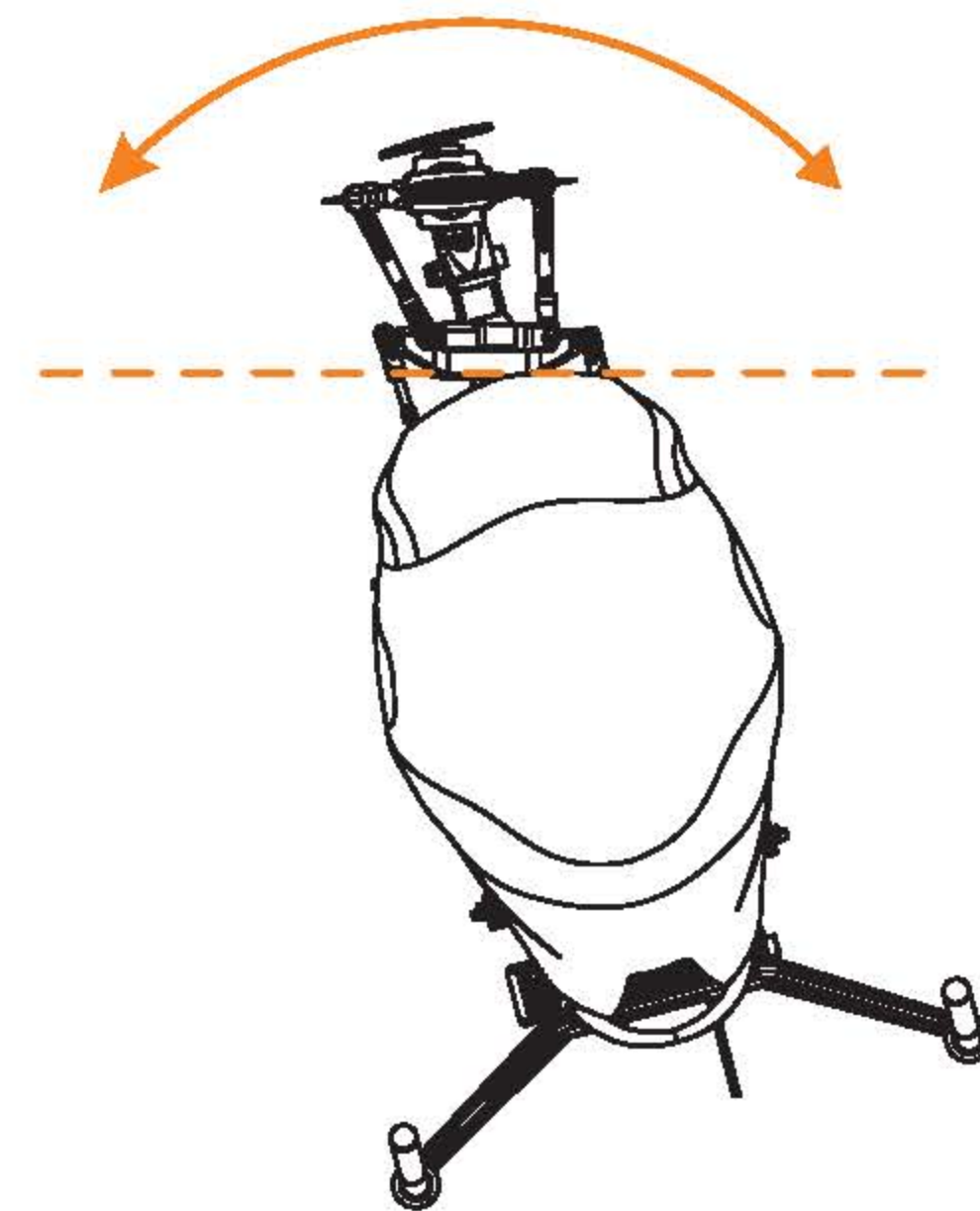
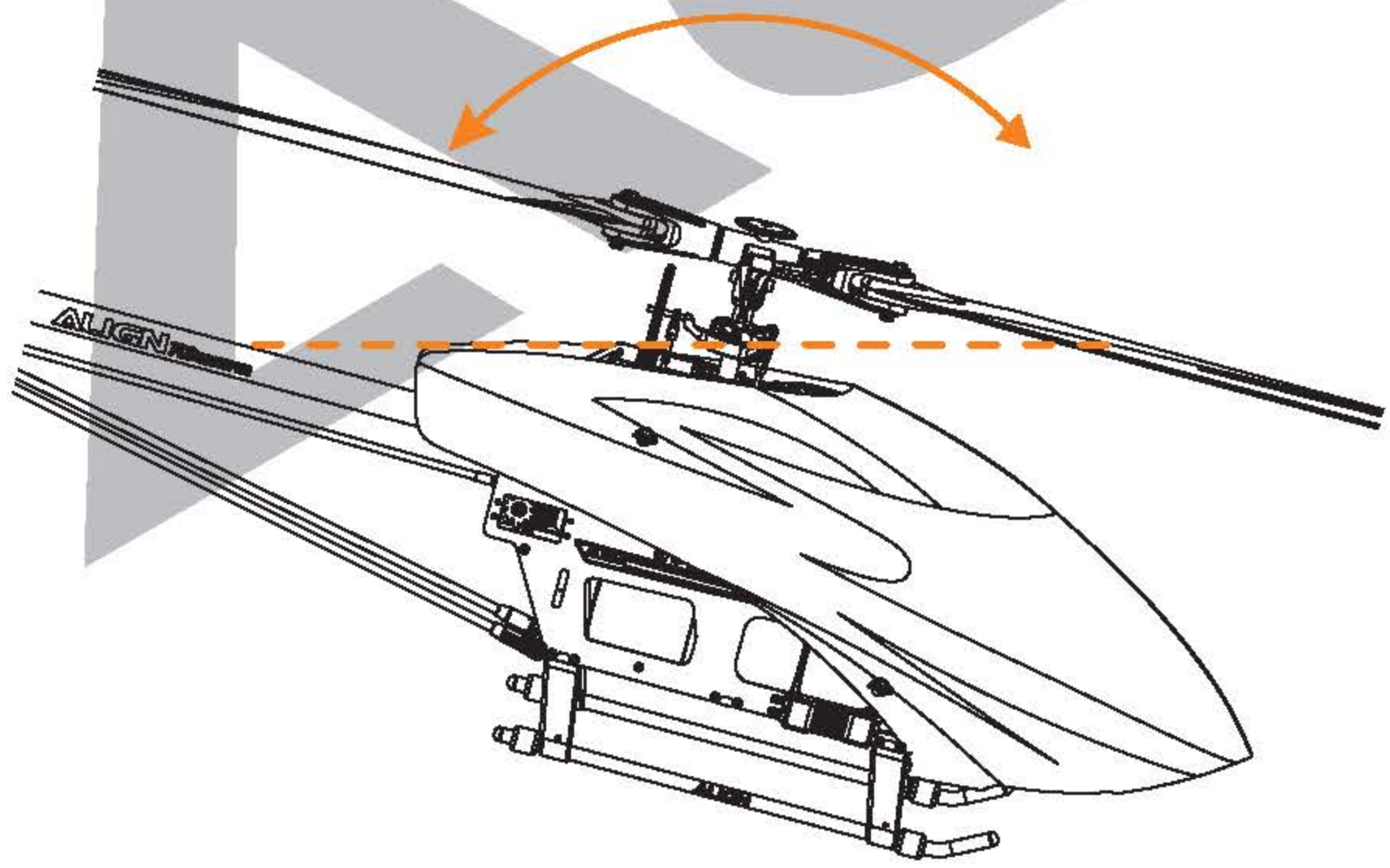

Status LED shows current swashplate gyro directions
Status-LED 燈顯示目前十字盤陀螺方向



Status LED changes color (= changing gyro direction)
Status-LED 燈改變顏色 (=改變陀螺方向)

Move Rudder Stick Left or Right
向左或向右移動尾舵搖桿



Press Button Briefly
短按按鈕

Status LED shows current swashplate gyro directions
Status-LED 燈顯示目前十字盤陀螺方向

SETUP MENU POINT N - INTERNAL RPM GOVERNOR

設定選單第 N 點-內建 RPM 定速模式

This menu point is only accessible if you're not using a Standard type receiver! Otherwise pressing the button at menu point M will exit the menu and lead back to operation mode.

Enable the internal RPM Governor function by choosing the type of drive system of your helicopter. If you're using the governor function of the ESC or an external governor or if you want to fly without headspeed governing at all, select "Governor off".

如果您不是使用傳統接收器，可略過此選單點！在選單第 M 點按下按鈕，退出選單回到操作模式。

選擇您直昇機的傳動方式，來開啓系統內建的 RPM 定速模式。如果您使用的是 ESC 變速器，或外接一個定速器，或不使用調速器等等，都請選擇「定速模式關閉」。

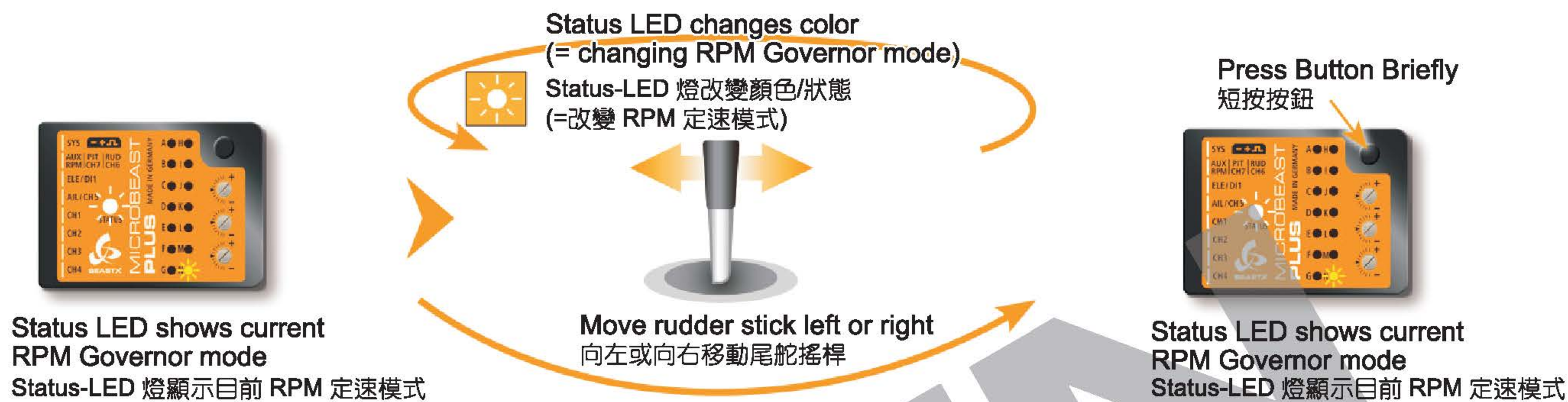

Status-LED Status-LED燈	Off 熄滅	Red 紅燈	Blue 藍燈
N Internal RPM Governor N 內建 RPM 定速模式	Governor Off* 定速模式關閉*	Electric Heli 電動直昇機	Nitro/Gas Heli 引擎直昇機

When you're using the RPM Governor of MICROBEAST PLUS now connect the RPM sensor (i. e. magnetical, optical or brushless phase sensor) or the wire for RPM signal of your ESC to the white sensorport on the long side. For this you may need the optional available BXA76401 adapter.

如果您要使用 MICROBEAST PLUS 的 RPM 定速模式，請連接一個轉速感應器(磁，光或無刷三相感應器)來發送 ESC 的轉速訊號給系統，連接端口在 MICROBEAST PLUS 側邊的白色插槽(如圖示)。您需要另購 BXA76401 連接線。

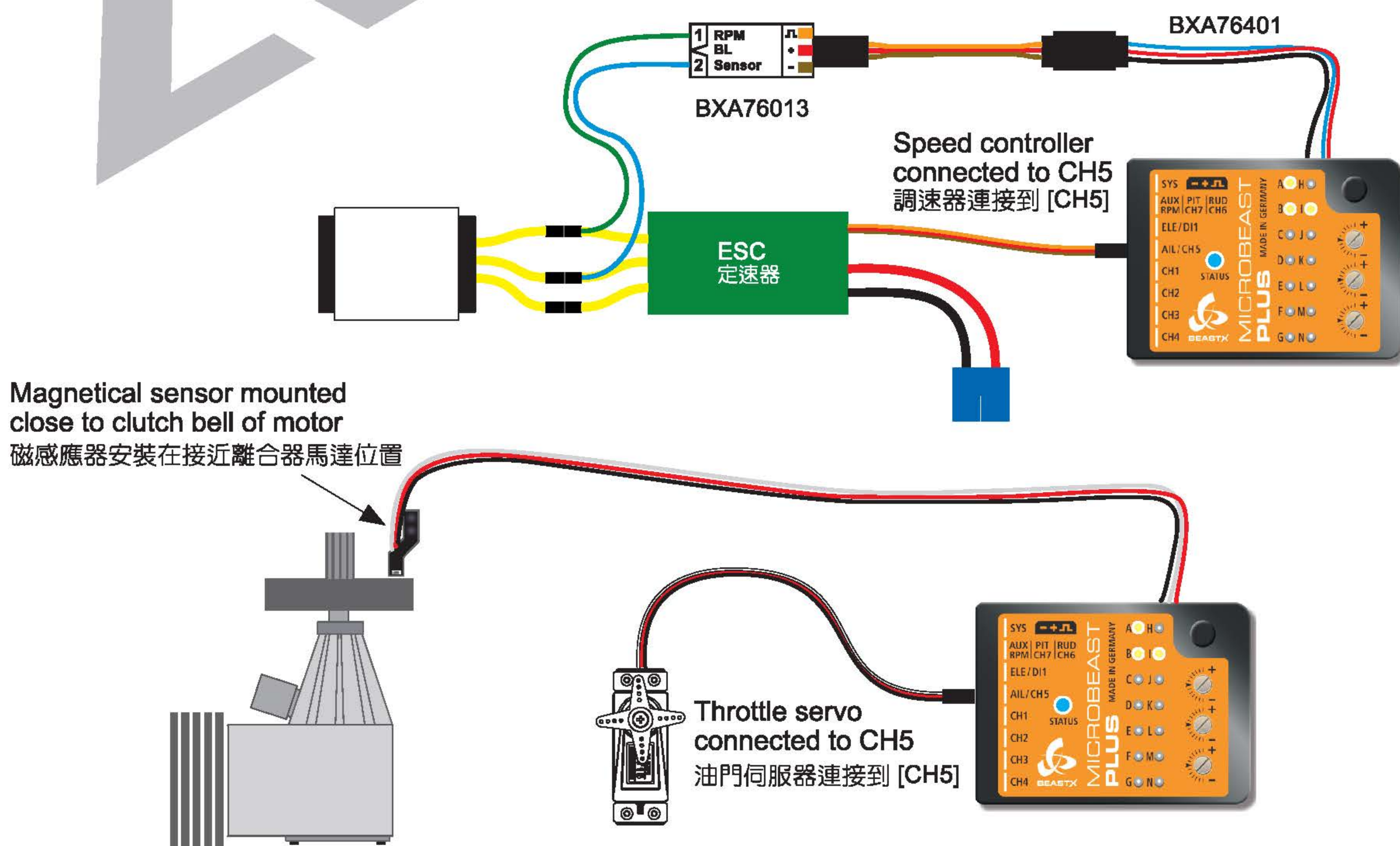

7 GOVERNOR SETUP MENU

定速模式設定選單

ALIGN

GOVERNOR MENU POINT A - TEST MODE (MENU LED A FLASHING SLOWLY) 定速模式設定選單第 A 點-測試模式(Menu LED 燈第 A 點慢速閃爍)

If the RPM Governor was activated at Setup menu point N (setting "electric" or "nitro/gas" heli) you can access the Governor menu immediately afterwards. At menu point A we check if the rpm sensor is functioning properly and if the rpm sensor wire is connected correctly.

如果在設定選單第 N 點開啓 RPM 定速模式(設定 "電動" 或 "引擎" 直昇機), 即可立即進入選單。在選單中的第 A 點, 我們要檢查的是轉速感應器的功能是否正常, 接線是否正確。

Electric Heli With Brushless Phase Sensor 電動直昇機含無刷相位感應器



Menu LED A flashes
Status LED off
Menu LED 燈第 A 點閃爍
Status-LED 燈熄滅



Carefully add throttle until motor starts to turn
Status LED is solid red as long as motor turns
請小心增加微量油門直到馬達轉動
Status-LED 燈恆亮紅色

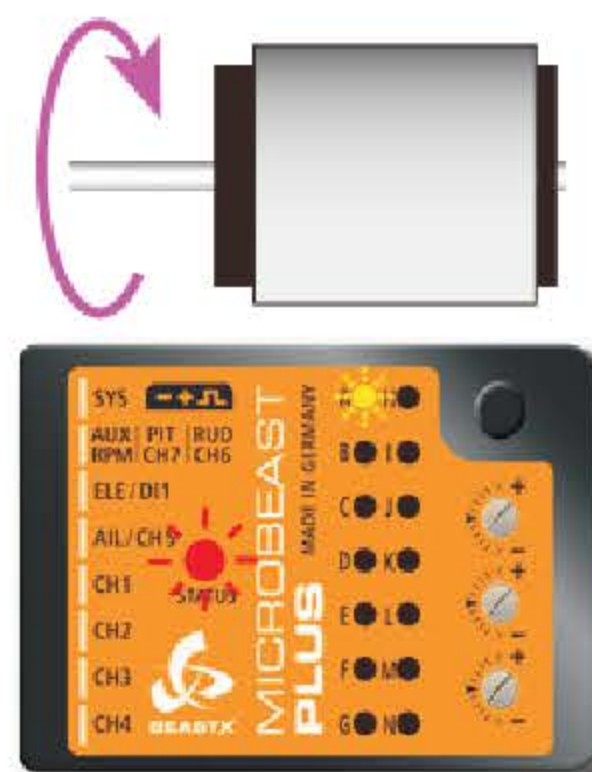

Stop
停止



Motor Off Position
馬達關閉位置



Press Button Briefly
短按按鈕



Menu LED A flashes
Status LED off
Menu-LED 燈第 A 點閃爍
Status-LED 燈熄滅

Nitro/Gas heli 引擎直昇機



Menu LED A flashes
Status LED off
Menu-LED 燈第 A 點閃爍
Status-LED 燈熄滅

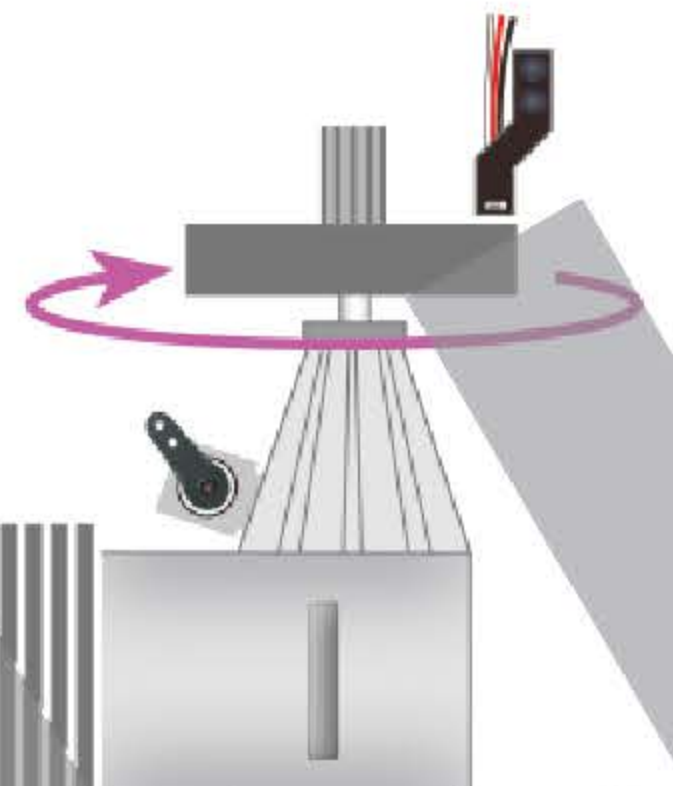

Turn clutch bell by hand
用手轉動離合器



Status LED solid blue
when magnet triggers sensor
當磁鐵觸發感應器,
Status-LED 燈恆亮藍色。

Press Button Briefly
短按按鈕



Status LED off when no magnet under sensor or when second magnet is passed (this may vary)
當感應器沒有接收到磁力訊號或傳送第二次磁力訊號(可能會改變), Status-LED燈熄滅。

Additionally when using a helicopter with combustion engine you may adjust the throttle servo positions in the transmitter (servo throw and servo center) and setup the throttle on the heli (throttle linkage rod length and servo arm position) if necessary. Attach the servo horn at thrust mid stick position. The throttle linkage must form a right angle with the servo horn.

Adjust the length of the linkage according to the instructions of the helicopter so that it also is positioned perpendicular to the linkage lever at the carburetor. The carburetor must be opened halfway (note the markings on the carburetor!). Then adjust the servo throw so the carburetor can be fully opened and fully closed without jamming the throttle servo.

若您使用的是引擎直昇機, 可在遙控器調整油門伺服器的位置 (伺服輸出和伺服中立點), 如果有必要, 也可以調整直昇機的油門伺服器的連桿長度和伺服臂位置。伺服器臂要在油門中立點的位置, 它和伺服器連桿頭必須成直角, 請參考下圖。

請根據直昇機的結構來調整連桿球頭的長度, 必須讓它的位置垂直於化油器的連桿控制臂。調整化油器控制臂時, 請將化油器開啓至一半的位置(請注意化油器的標記!)。然後調整伺服器輸出的最大及最小行程量, 並注意其順暢度。

Thrust in Mid Stick Position
螺距搖桿在中立點位置



Servo arm and throttle lever in parallel and perpendicular to linkage rod
伺服器臂及油門控制臂經由連桿互相平行並垂直

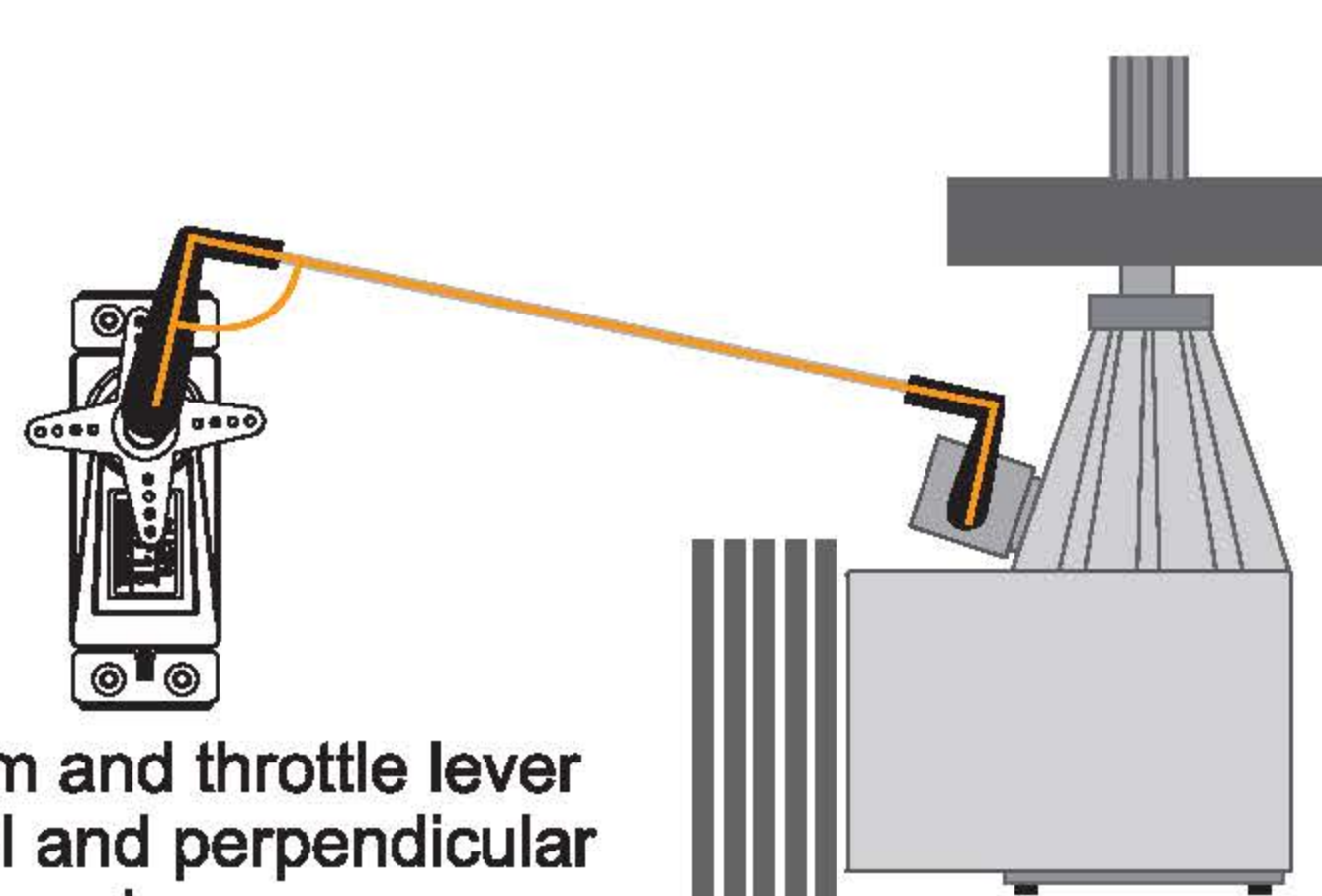

GOVERNOR MENU POINT B - MOTOR OFF/IDLE POSITION

定速模式選單第 B 點-馬達開啓/關閉位置

Using an electric heli move the throttle to the position at which the motor is just before to start running, i.e. by adding throttle until the motor starts to turn and then reducing the throttle a little. With a nitro/gas heli move the throttle to a stable idle position.

使用電動直昇機請將油門移動到開啓馬達前的位置，接著慢慢增加油門，直到馬達開始轉動，然後稍微降低一點油門。當使用引擎直昇機時，請將移動到油門怠速位置。



Menu LED B flashes
Status LED off
Menu-LED 燈第 B 點閃爍
Status-LED 燈熄滅

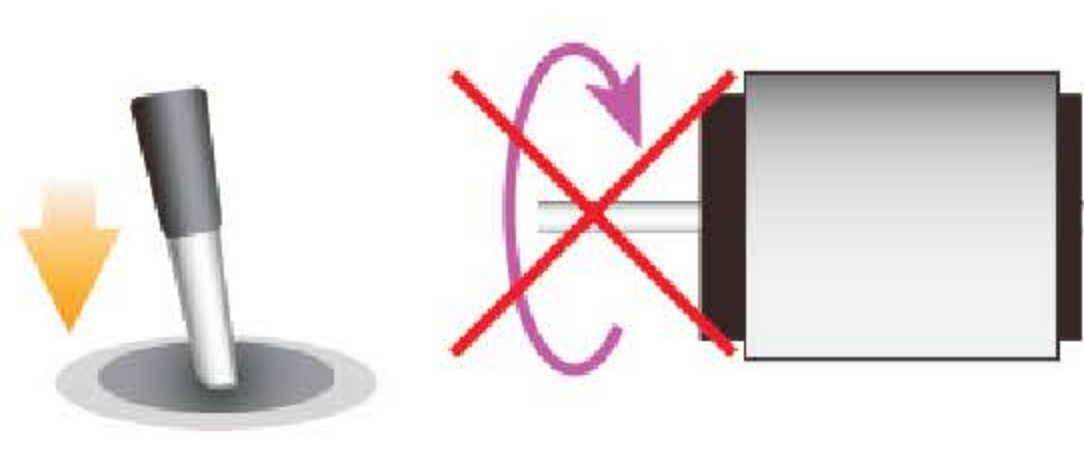

Move throttle to position at which the motor is just before to start running (electric heli) or idle position (nitro/gas heli)
移動油門到馬達開啓前的位置(電動直昇機)或油門怠速位置(引擎直昇機)

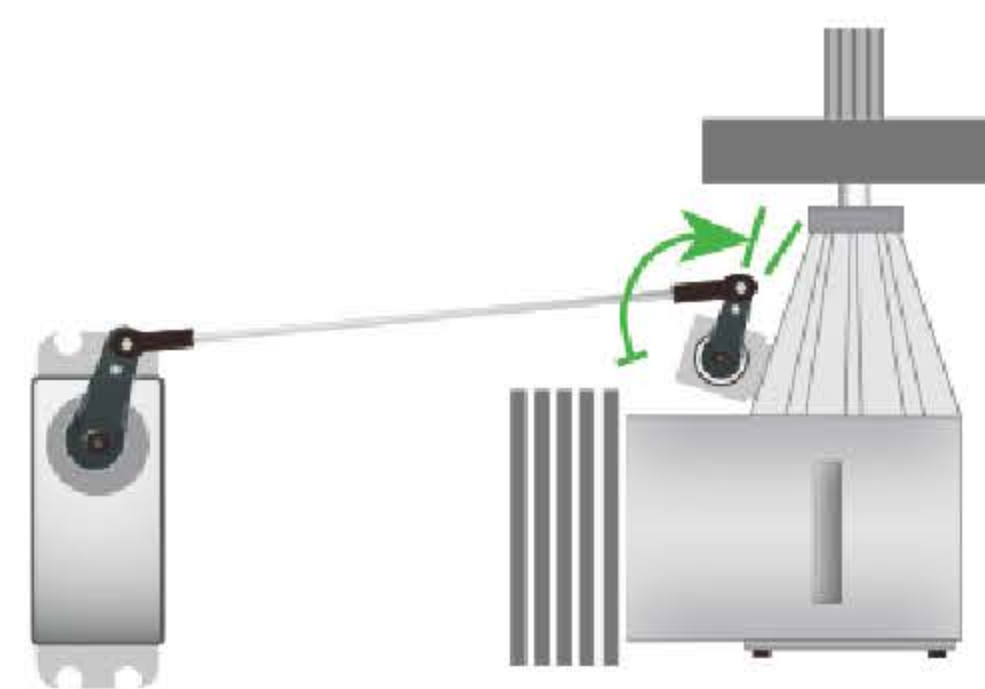

Press Button Briefly
短按按鈕



Status LED blue when throttle position registered
開啓油門位置時，
Status-LED 燈亮藍色

GOVERNOR MENU POINT C - FULL THROTTLE POSITION

定速模式選單第 C 點-油門最大行程量

Move throttle to maximum position. Note: In electric governor mode the throttle input will not be passed to CH5 output to prevent from motor damage by running the motor without load! Thus, you have to check before that the full throttle position runs the motor at maximum speed in reality, i.e. by correctly programming your throttle end points in the transmitter or ESC.

將油門推到最大行程的位置。請注意：在電動直昇機變速器(ESC)的模式下，為了防止空載而損壞馬達，油門輸入將不會經由 [CH5] 傳輸出來！因此，您必須在馬達實際運轉前，檢查最大行程量，請直接操作遙控器或變速器油門的最大及最小行程量。



Menu LED C flashes
Status LED off
Menu-LED 燈第 C 點閃爍
Status-LED 燈熄滅

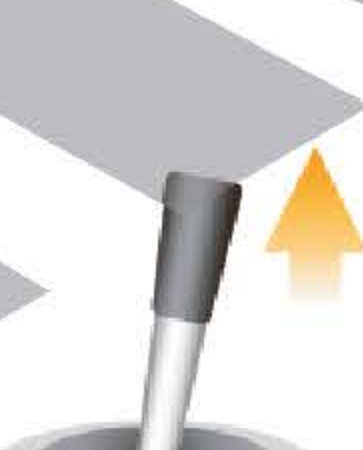

MAX RPM
最大轉速

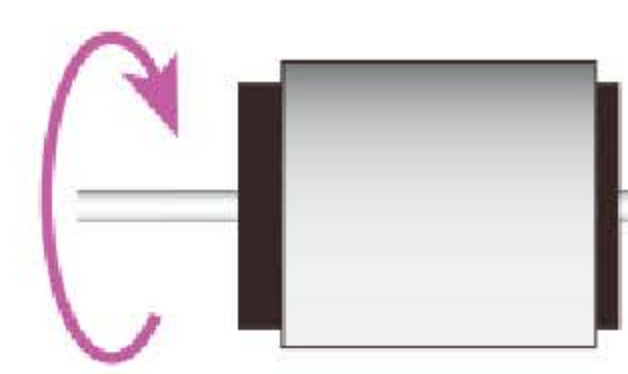

Move throttle to maximum position
移動油門到最大行程量

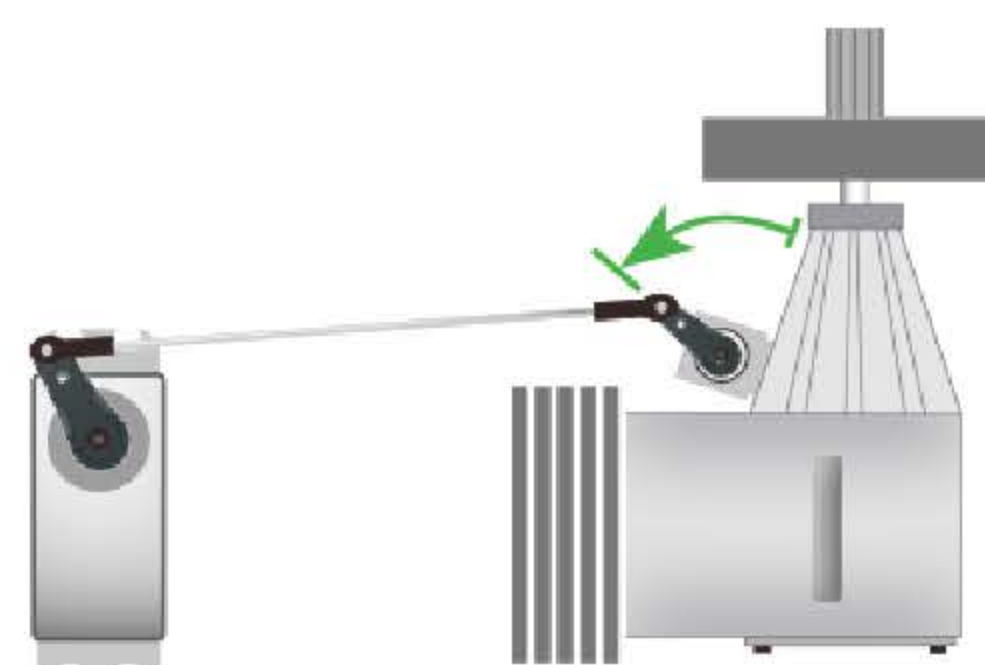

Press Button Briefly
短按按鈕



Status LED blue when throttle position registered
啓動油門位置時，
Status-LED 燈亮藍色

GOVERNOR MENU POINT D - TRANSMITTER SETUP

定速模式選單第 D 點-遙控器設定

Here we can set the desired rotor headspeed and throttle curves. The Status LED can be used to verify the transmitter setup. When using an electric heli the throttle is completely independent from the thrust stick. The throttle curves are set to horizontal lines which stand for a certain headspeed and governor operation mode. Using the flight mode switch you can switch between the different curves in the transmitter.

在這裡我們可以設置想要的旋翼頭轉速和油門曲線。Status-LED 燈，可以驗證遙控器的設定是否正確。使用電動直昇機時，油門是完全獨立於推力搖桿。油門曲線是根據旋翼頭轉速和定速模式來決定水平位置。請使用飛行模式開關，以便您在遙控器上切換不同曲線。

Motor off

- Throttle 0% over the entire range

馬達關閉

- 全部範圍的油門=0%

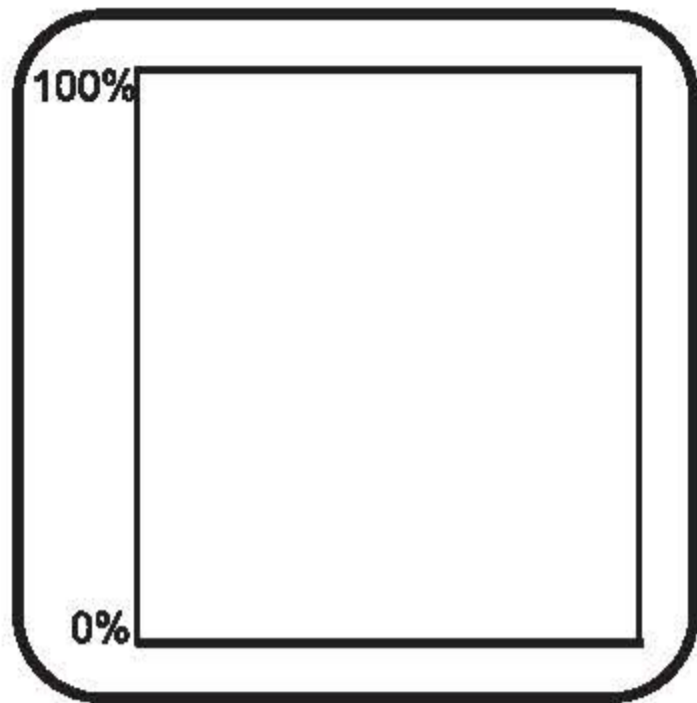

Status LED Off
Status-LED 燈熄滅

Idle Up

- Throttle set between 15% and 100% equals headspeed of 600-4000rpm
- +5% = +200rpm

Idle Up

- 油門設定在 15% 和 100% 之間等於頭速 600-4000rpm
- +5% = +200rpm

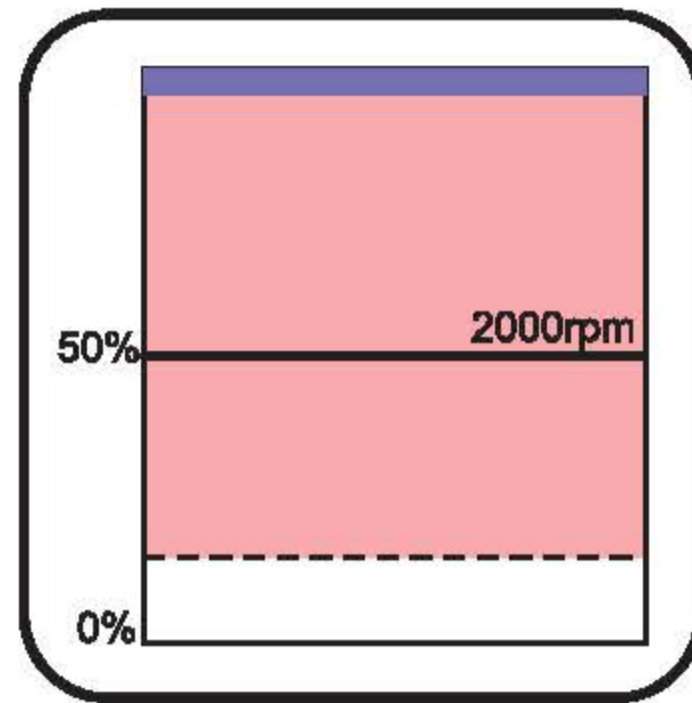

Status LED Red or Purple
Status-LED 燈紅色或紫色

Autorotation

- Motor off
- When switching back to idle up motor will restart quickly

熄火(降落)

- 馬達關閉
- 當切換回 Idle Up，馬達會快速重新啓動

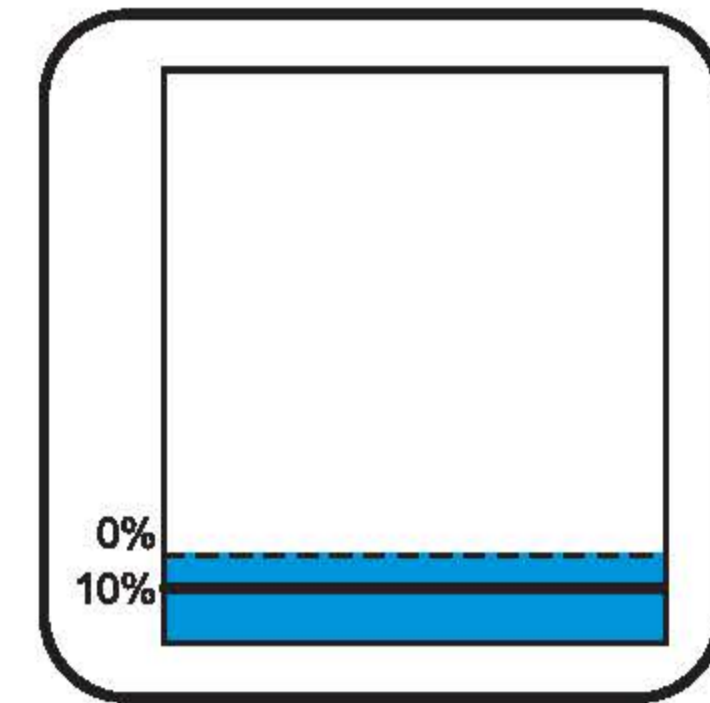

Status LED Blue
Status LED 燈藍色

The RPM Governor for **nitro/gas models** can be operated in two different ways. One possibility is to operate the governor using the throttle channel just like in electric mode. Only difference is that the the range below 50% throttle can be used to manually control the throttle servo, i.e. for starting the motor. When the motor is running you can switch in the area above 50% which is used to enable the governor and preset a specific rotor headspeed.

引擎直昇機的 RPM 定速模式有兩種不同的操作方式。其中一種是使用油門通道，這和電動模式的定速方法相同。唯一不同的是，它在油門 50% 以下的範圍內，能允許手動控制模式來操控油門伺服器。當馬達運轉高於 50%，您可以切換定速器，並預設特定的旋翼頭速。

Manual control

- Range between 0% and 50% directly controls the throttle servo

手動控制模式

- 0% 至 50% 範圍內直接控制油門伺服器

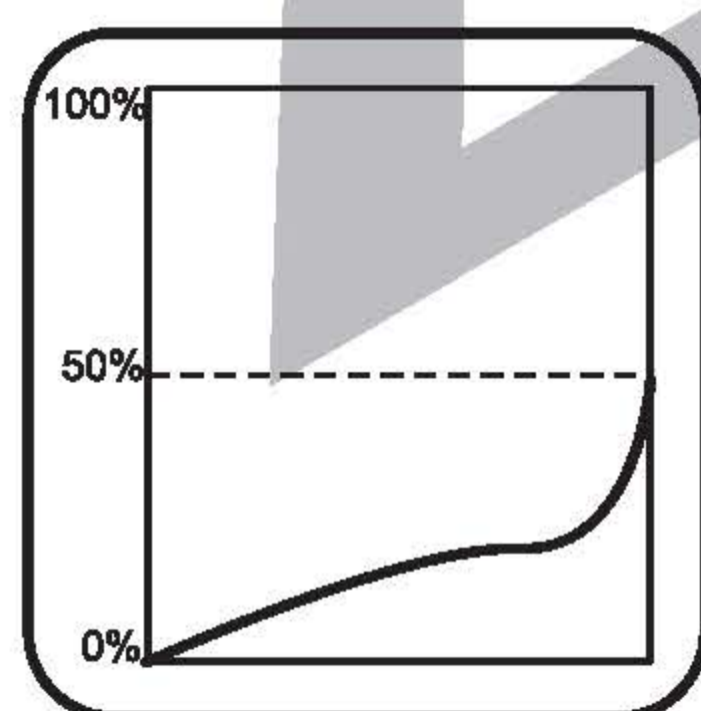

Status LED Off
Status-LED 燈熄滅

Idle Up

- Throttle set between 50% and 100% equals headspeed of 600 - 3000rpm
- +5% = +240rpm

Idle Up

- 油門設定在 50% 與 100% 之間，等於頭速 600 - 3000rpm
- +5% = +240rpm

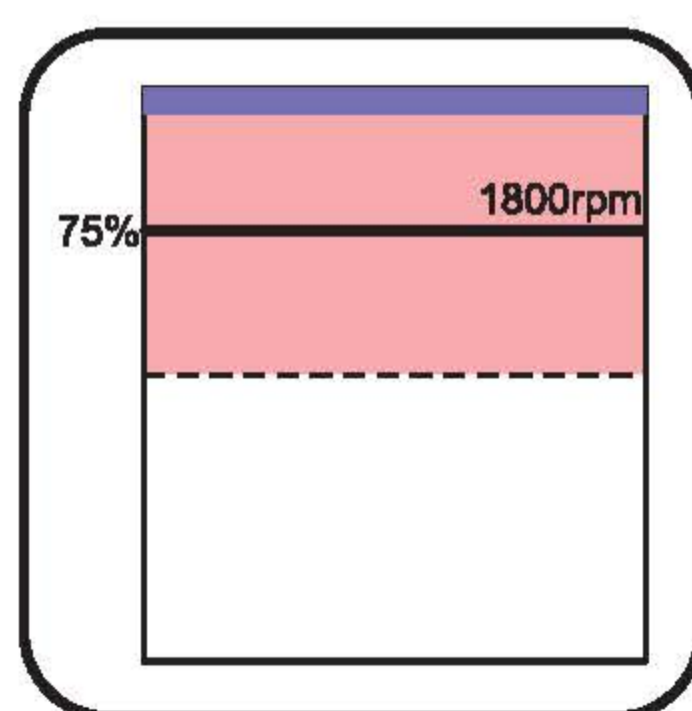

Status LED Red or Purple
Status-LED 燈紅色或紫色

Autorotation

- Throttle in idle position
- When switching back to idle up (>50%) motor will restart quickly
- Switching back to manual control (<40%) will disable governor

熄火(降落)

- 油門在 Idle 位置
- 當切換回 idle up (>50%)，馬達會快速重新啓動
- 切換回手動控制 (<40%)，會禁用定速模式

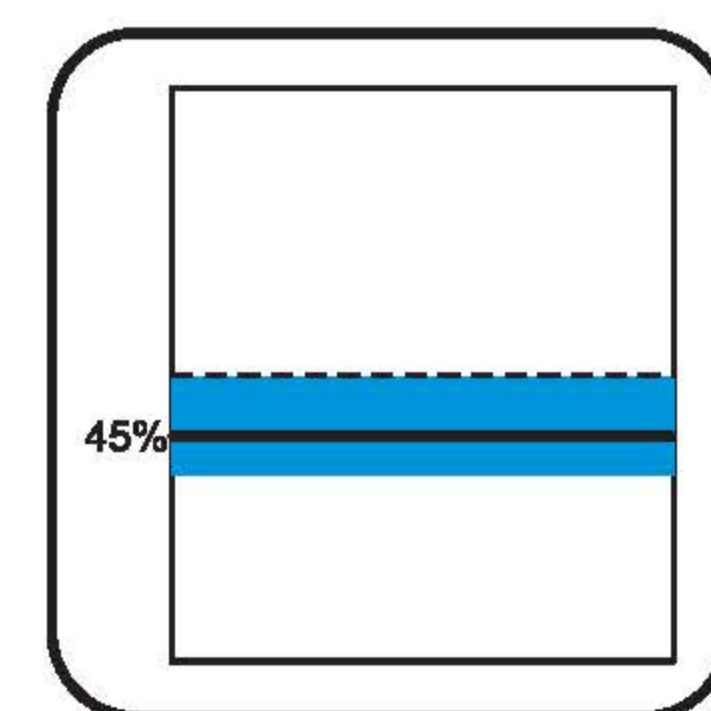

Status LED Blue
Status LED 燈藍色

The second option to control the RPM Governor for nitro/gas helicopters is to use a separate switch channel. Here you can use the throttle curves to manually control the throttle servo completely. The RPM Governor is activated and the headspeed is preset by using the additional channel. When the throttle channel is above 25% and a headspeed is preset, the RPM Governor will control this headspeed. Moving the throttle below 25% will set Autorotation mode while the RPM Governor is still activated in the background.

第二個方法是將 RPM 定速模式分配在一個獨立的控制通道。這樣，您就可以利用油門曲線完全手動控制油門伺服器。開啓 RPM 定速模式，利用獨立的通道預設旋翼頭速。當油門高於 25% 且已預設頭速時，RPM 定速模式會介入控制頭速。若在 RPM 定速模式仍然開啓的情況下，移動油門低於 25%，系統會轉入熄火降落模式。

Manual Control

- Throttle curve controls (Throttle Channel) servo
- Governor off
- Governor channel below 5% (-90)

手動控制模式

- 油門曲線控制伺服器
- 定速模式關閉
- 定速模式通道低於 5% (-90)

Throttle Curve (Throttle Channel)
油門曲線 (油門通道)

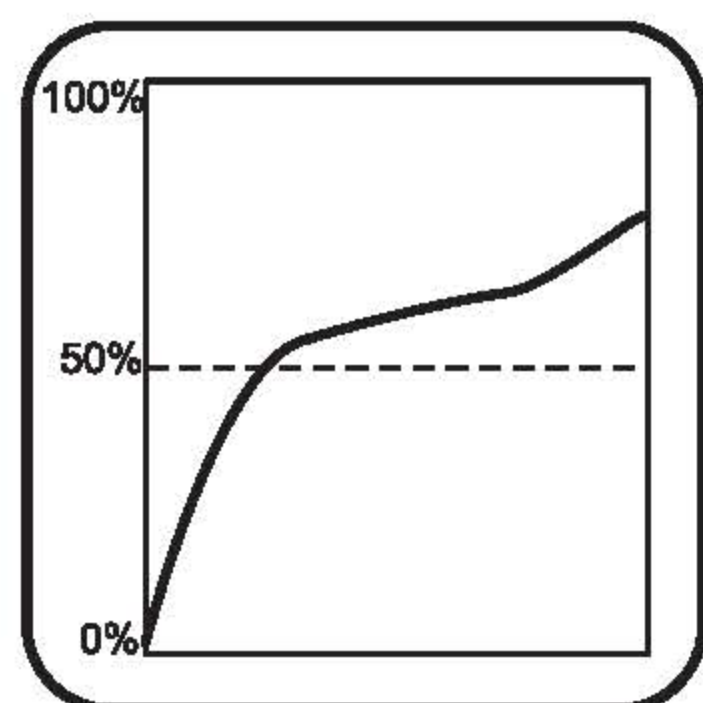

Status-LED off
Status-LED 燈熄滅

Governor Control Channel
定速模式控制通道

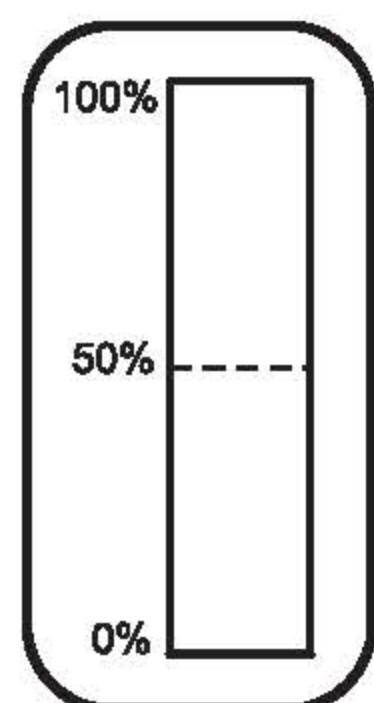

Idle Up

- Governor channel set between 5% and 100% (or -90 and +100 on some transmitters) equals headspeed of 600-3000rpm
- +5% (or 10 clicks) = +126rpm
- throttle channel must stay above 25%

Idle Up

- 定速模式通道設定在 5% 至 100% 之間(或一些遙控器是 -90 至+100)等於頭速 600-3000rpm
- +5% (or 10 clicks) = +126rpm
- 油門曲線需高於 25%

Throttle Curve (Throttle Channel)
油門曲線 (油門通道)

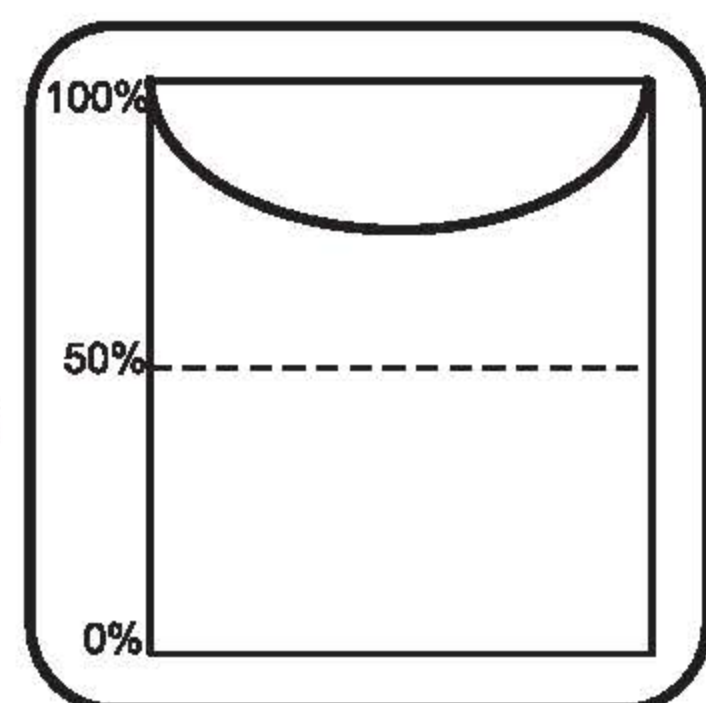

Status LED Red or Purple
Status-LED 燈紅色或紫色

Governor Control Channel
定速模式控制通道

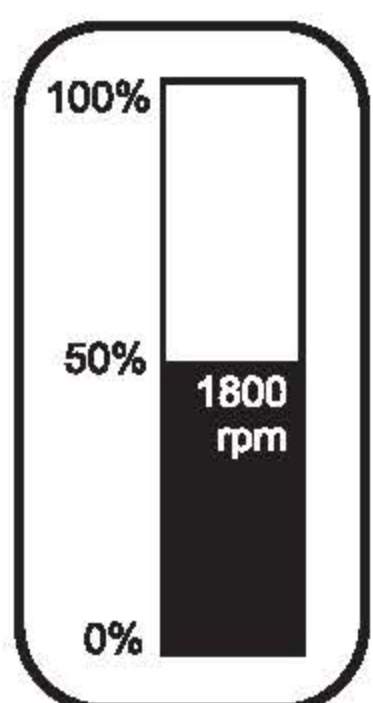

GOVERNOR MENU POINT E - SIGNAL DIVIDER

定速模式選單第 E 點-轉速訊號分配表

Electric helicopter with brushless phase sensor or phase signal from ESC: signal divider = motor pole count : 2

Nitro/Gas helicopter with magnetical or optical sensor: signal divider = number of triggers (i.e. magnets or optical markers)

電動直昇機搭配無刷相位感應器或 ESC 相位訊號：轉速訊號分配表=馬達極速：2

引擎直昇機磁或光感應器：訊號分配表 = 觸發 (如磁鐵或光學標記)的數量

Status-LED Status-LED燈	Off 熄滅	Flashing Purple 紫燈閃爍	Purple 紫燈	Flashing Red 紅燈閃爍	Red 紅燈	Flashing Blue 藍燈閃爍	Blue 藍燈
E Signal Divider 訊號分配表	1	2	3	4*	5	6	7

GOVERNOR MENU POINTS F G H - MAIN GEAR RATIO

定速模式選單第 F / G / H 點之主齒輪比

When the helicopter has a single stage main gear: Main gear ratio = Main gear tooth count : Motor pinion tooth count

Set the Status LED color/state at each of the menu points F, G and H so that the main gear ratio can be calculated as sum of the three menu points, i. e. 8.55:1 = F flashing purple + G purple + H flashing red

若使用單一主齒輪的直昇機時，主齒輪比=主齒輪齒數：馬達齒輪齒數

在設定選單中第 F/G/H 點的狀態指示燈來代表齒輪比，例如 8.55 : 1= 選單第 F 點閃爍紫色 + 選單第 G 點紫色+ 選單第 H 點為紅色閃爍

Status-LED Status-LED燈	Off 熄滅	Flashing Purple 紫燈閃爍	Purple 紫燈	Flashing Red 紅燈閃爍	Red 紅燈	Flashing Blue 藍燈閃爍	Blue 藍燈	Red / Blue 紅色/藍色
F	User Defined 使用者自訂義	8.00	9.00*	10.00	11.00	12.00	13.00	14.00
G	+0.00	+0.20	+0.40*	+0.60	+0.80	——	——	——
H	+0.00	+0.05	+0.10*	+0.15	——	——	——	——

8 FLYING AND OPTIMIZATION

飛行及優化飛行

ALIGN

The **tail gyro gain** is adjusted by one of the transmitter's auxiliary channels. The more servo throw this channel produces, the higher the tail gyro gain will be. Additionally the direction of servo throw determines whether the gyro works in Normal-Rate mode or in HeadingLock mode. The color of the Status-LED indicates the selected mode when MICROBEAST PLUS is ready for operation. Purple indicates Normal-Rate mode and blue indicates HeadingLock mode. While adjusting the gain and shortly after the first power up the current amount of gain is displayed by one of the menu LEDs for 8 seconds.

您可以利用遙控器的輔助通道來調整尾陀螺儀感度。在這個通道發射越多伺服訊號，就會有越高的尾陀螺儀感度。伺服訊號輸出的方向決定陀螺儀的工作模式，分別為「鎖定模式」或「非鎖定模式」。Status-LED 燈的顏色表示在目前的工作模式下，MICROBEAST PLUS 已準備就緒。紫燈表示「鎖定模式」，藍燈表示「非鎖定模式」。調整好感度的首次啟動時，請輕推一下搖桿，當前感度值會在一個設定選單的 LED 燈顯示約 8 秒。



For the first flight we suggest to start with medium gain (not higher than LED G) and using HeadingLock mode (Status LED blue). In case the tail of the helicopter starts to oscillate in flight immediately reduce the gain! If the tail rotor control feels weak and imprecise and the tail does overshoot when stopping and doesn't hold position increase the gain. Most radio controls provide an automatic switching for the tail gyro gain depending on flight modes. In the flight mode with the lowest rotor headspeed you can use the most tail gain. Reduce the gain the higher the headspeed is. Before the first flight make sure the tail gain is set correctly and is also set when switching flight modes.

Adjusting the three dials on top of MICROBEAST PLUS you can optimize the control loop and customize it to your helicopter. For the first flight all three dials should be centered. If necessary only adjust one dial at a time and only in little steps. Turning a dial clockwise will increase the effect, turning it counter-clockwise will decrease the effect of the parameter.

在鎖定模式下 (Status-LED 燈亮藍色) 的首次飛行時，我們建議您將感度設在 50% (以不超過 LED 燈 G 以上，請參考上圖)。低感度在飛行時會覺得無力，且會有追尾的現象產生。大多數品牌的遙控器在某種飛行模式下，可自動切換尾陀螺儀感度。在飛行模式下的頭速設定，建議您用最高感度。降低感度來提高頭速也是可以的。首次飛行前，請務必檢查尾陀螺儀感度，以及飛行模式的切換是否正確。

調整 MICROBEAST PLUS 面板上的三個旋鈕，可以優化您直昇機的飛行效果。首次飛行時，面板上的三個旋鈕的感度應在水平位置。如有必要，請一次只調整一個旋鈕。若順時針方向轉動旋鈕，感度會增加。反之，逆時針方向旋轉旋鈕，感度會降低。

1- Cyclic Gain

In general the higher the gain the harder the helicopter will stop after cyclic moves and the more stable and precise the helicopter will fly. If the gain is too high the helicopter will tend to oscillate at high frequency especially on the elevator axis. Due to their low mass this behavior will occur sooner on small helicopters, so typically these do not need as much gain as large helicopters. With low gain the helicopter does not stop precisely and overshoots after a cyclic movement. Additionally it is unstable and control feels sluggish in fast forward flight and when hovering.

1-循環螺距感度

一般來說，感度越高，在循環螺距變化後，直昇機的停止動作就會越硬，這樣會使得停懸會比較穩定。但是，如果感度太高，直昇機在上下飛行時會有回彈追尾的現象產生，並且容易抖動。由於這些現象大多發生在較小型的直昇機上(450級含以下)，所以，大型直昇機並不需要太大的感度。如果感度太低，直昇機的停止動作將不準確，直線快速飛行和停懸時會感覺遲鈍不穩定。



2- Cyclic feed forward

If the cyclic feed forward is too high the stick input will over control the cyclic input. The heli will bounce back stopping from a cyclic movement. Also the helicopter will react over sensitive and it will pitch up easily a stick input is applied in fast forward flight. If the cyclic feed forward is too low on the other hand the control appears delayed and feels very robotic and unnatural.

2-十字盤直接輸出量

如果十字盤直接輸出量過高，當在打舵時，過大的十字盤反應，會使得直昇機有停頓回彈的現象產生，也會覺得直昇機的反應過度敏感，同時，當增加感度時，直昇機會快速向前飛。反之，如果十字盤直接輸出量過低，會出現延遲現象和感覺非常機械化和不自然。

3- Tail gyro response

Increasing the tail gyro response will lead to harder stopping and more aggressive response to rudder stick inputs. If the response is too high the tail will bounce back shortly after a hard stop and feels spongy when making fast direction changes. If the dynamic is set too low the rudder control feels dull and stopping might be too soft. Ideally the tail should stop perfectly to the point without making any flapping noises.

3-尾舵動態反應

增加「尾舵動態反應」的感度，會導致直昇機降落時的動作較僵硬及敏感。如果反應太過敏感，直昇機在硬著陸時，尾部會有短暫回彈的現象產生，以及在快速變化方向時，感覺軟力。如果感度太低，在打方向舵時，會感到遲鈍和軟力。理想情況是直昇機在降落時，尾部要完全停止，沒有任何阻力產生。

Before the first take off, make a stick direction check and again make sure that the sensors are correcting to the right direction when you tilt, roll or yaw the helicopter by hand. Just before lift-off make sure that the swashplate is horizontal and that the tail pitch slider is near center. You can shortly switch the tail gyro to Normal-Rate mode, in this mode the rudder servo will center itself if the rudder stick is released. Avoid excessive steering during lift-off, otherwise the helicopter may tip over as it can't move as long as it's still standing on the ground! The best way is to give a fair and direct collective pitch input to lift the helicopter quickly up into the air.

在首次飛行前，最好再做一次檢查，例如用手撥動搖桿，看十字盤運動方向是否正確，左右或前後傾斜直昇機，看伺服器是否會做出確的方向補償。請記住，在升空前十字盤是呈水平的位置，尾舵感度接近中立點。您可以簡單的將尾舵螺儀移動到非鎖定模式，在此模式下，放開尾舵搖桿，尾舵伺服器會自行回中。請注意，起飛前請不要過度傾斜，否則，只要直昇機無法起飛，就有可能會傾倒，最好的方式是先打一個少量的循環螺距，讓直昇機可以快速的升空。

9 PARAMETER MENU

參數選單

ALIGN

The Parameter menu allows you to further customize the flight characteristics of the helicopter and the reaction of the system to control inputs. You can find a detailed description for each parameter in the MICROBEAST PLUS instruction manual.

參數選單，方便您調整直昇機的飛行特性及控制反應。您可以在 MICROBEAST PLUS 說明書中找到每個參數的詳細說明。

Entering Parameter Menu 進入參數選單

Press and Hold Button
長按按鈕

Release Button
放開按鈕

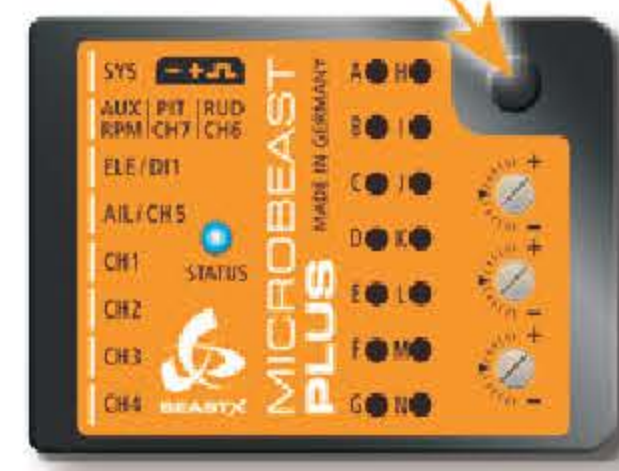

Operation Mode
(Status LED is Blue or Purple)
操作模式(Status LED燈藍色或紫色)

Menu LED A Flashing
Menu LED燈第 A 點閃爍

Menu LED A Flashing
(= Parameter menu point A)
Menu LED燈第 A 點閃爍(=參數第 A 點)

MENU POINT A - SWASHPLATE QUICK TRIM (MENU LED A FLASHING) MENU LED燈第 A 點-十字盤快速微調(=選單第 A 點閃爍)

Move the stick(s) for aileron and elevator to trim the swashplate into the desired direction. When using the tail gyro in Normal- Rate mode you can store the last servo position by pressing and holding the button for 2 seconds. To delete all trimmings that have recently been made briefly push the rudder stick.

移動副翼和升降搖桿來微調十字盤到所需的方向。在非鎖定模式下使用尾陀螺儀，只要按住按鈕 2 秒鐘即可存儲最後伺服器的位置。短暫地移動尾舵搖桿即可將先前的微調紀錄刪除。

MENU POINTS B TO K 選單第 B-K 點

Color and state of the Status LED indicate which option is currently selected at each menu point. By pushing the rudder stick repeatedly you can cycle through the available options at each menu point and change the setting if necessary. Briefly pushing the button will skip to the next menu point. After the last menu point the system will exit Parameter menu and change back to operation mode.

Status-LED 燈的顏色顯示您在每個選單中的當前選項。利用反覆朝一個方向推動尾舵搖桿，直到 Status-LED 燈出現需要的顏色為止。短按按鈕就會跳到下一個選單點。到達最後一個選單點後，系統將退出參數選單，回到操作模式。

Status-LED Status-LED燈	Off 熄滅	Purple 紫燈	Flashing Red 紅燈閃爍	Red 紅燈	Flashing Blue 藍燈閃爍	Blue 藍燈
B Control Style B 控制風格	User Defined 使用者自訂義	Normal 普通	Sport* 運動*	Pro 緩和	Extreme 極限	Tx Mode 遙控器
C Speed Flight Stability C 高速飛行穩定性	User Defined 使用者自訂義	very low 極低	Low 低	Medium* 普通*	High 高	Very High 極高
D RUDDER RATE CONSISTENCY D 尾舵率一致性	User Defined 使用者自訂義	very low 極低	Low 低	Medium* 普通*	High 高	Very High 極高
E Stick Deadzone E 搖桿死區	User Defined 使用者自訂義	very small 極小	Small* 小*	Medium 普通	Large 大	very large 極大
F Torque Precompensation F 反扭力補償	User Defined 使用者自訂義	Off	low - nor. 低-正	High - Nor. 高-正	Low - Inv. 低-逆	High - Inv. 高-逆
G Cyclic Response G 循環反應	User Defined 使用者自訂義	Normal* 普通*	Slightly Increased 增加一點	Increased 增加	Aggressive 激進	Very Aggressive 極激進
H Pitch Boost H 螺距增強	User Defined 使用者自訂義	Off*	Low 低	Medium 普通	High 高	Very High 極高
I Throttle Response I 油門反應	Soft 緩和	Normal* 普通*	Slightly Increased 增加一點	Increased 增加	Aggressive 激進	Very Aggressive 極激進
J Slow Ramp Up Speed J 緩啟動速率	User Defined 使用者自訂義	50 rps	100 rps	200 rps	300 rps	300 rps
K Fast Ramp Up Speed K 快速啟動速率	User Defined 使用者自訂義	Using Slow Ramp Up Speed 採用緩啟動速率	300 rps	500 rps	700 rps	700 rps

10 ATTITUDE CONTROL (OPTIONAL)

姿態模式(另購)

ALIGN

The Parameter menu allows you to further customize the flight characteristics of the helicopter and the reaction of the system to control inputs. You can find a detailed description for each parameter in the MICROBEAST PLUS instruction manual.

參數選單，方便您調整直昇機的飛行特性及控制反應。您可以在 MICROBEAST PLUS 說明書中找到每個參數的詳細說明。

PARAMETER MENU POINT L - ATTITUDE CONTROL MODE

參數選單第 L 點-姿態模式

AttitudeControl can be used to level the helicopter automatically by the flip of a switch. This provides different applications i.e. to use as bail out rescue in case the pilot loses orientation, to have a training aid for learning new flight maneuvers or to use as stabilization for camera flights. At Parameter menu point L you can choose between different operation modes and applications that determine how the helicopter will be stabilized exactly when activating AttitudeControl in flight. Please see the instruction manual for further reference. For the beginning we recommend using the "Rescue mode with pitch control".

姿態模式可以利用一個開關來回正直昇機。這個功能有許多不同的運用，例如當飛行員失去方向時，可做為失控保護救援功能，還可用來學習特技飛行的動作，或著，在搭載相機時能自穩飛行以防止抖動。在飛行時開啓姿態模式，系統會在不同的操作模式和應用程序之間進行選擇，然後精確地穩定直昇機的飛行。請參閱說明書參數選單第 L 點。初始飛行時，我們建議您使用失控保護模式-螺距控制。

Status-LED Status-LED燈	Off 熄滅	Flashing Purple 紫燈閃爍	Purple 紫燈	Flashing Red 紅燈閃爍	Red 紅燈	Blue 藍燈
L AttitudeControl Operation Model L 姿態模式	Attitude Control Disabled* 停用姿態模式*	Bail Out Rescue 失控保護	Bail Out Rescue W. Pitch Control 失控保護及螺距控制	3D Mode 3D模式	3D Mode w. pitch control 3D模式及螺距控制	Flight Trainer 飛行訓練

PARAMETER MENU POINT M - ATTITUDE CONTROL PITCH

參數選單第 M 點-姿態模式螺距

When you choose an AttitudeControl mode "with pitch control" at menu point L additionally menu point M will appear after pressing the button at L. Here you can adjust the collective pitch that will be used when AttitudeControl is activated and the heli is hovering stable. Use the stick for aileron to adjust the pitch if necessary.

當您選擇姿態模式，在選單第 L 點及第 M 點，在按下按鈕後會出現 "with pitch control"，如果這時姿態模式已經開啓，您就可以在這裡調整循環螺距讓直昇機在停懸時更穩定。如有需要，也可使用副翼搖桿來調整螺距。

TRANSMITTER PROGRAMMING

遙控器編程

In case AttitudeControl has been enabled at Parameter menu point L you can activate it in flight by moving the channel for AttitudeControl into one direction. There are 2 options for the control channel: Either you use a separate switch channel that can be assigned in Receiver setup menu (or which is set by default) or you use the tail gyro gain channel also for adjusting AttitudeControl. While in operation mode you can check if activating AttitudeControl is working properly.

Whenever the AttitudeControl status changes the Status LED will light solid red and the Menu LEDs indicate whether AttitudeControl is on or off and how strong it will react. After 8 seconds the display changes back to showing the tail gyro operation mode.

如果在參數選單第 L 點啓用姿態模式，您可以在飛行時將姿態模式的通道往一個方向移動來開啓它。系統提供兩個方法來設定姿態模式的控制通道：(一)利用接收器設定選單，指定一個單獨的通道(或預設通道)；(二)利用尾陀螺儀感度通道。而在操作模式中，您可以檢查姿態模式是否已經開啓，以及運作是否正常。每當姿態模式的狀態更改時，Status-LED 燈會恆亮紅色，Menu LED 燈(感度)表示姿態模式的狀態是在「開啓」或「關閉」，以及反應的強度。8秒之後，系統會返回尾陀螺儀操作模式。

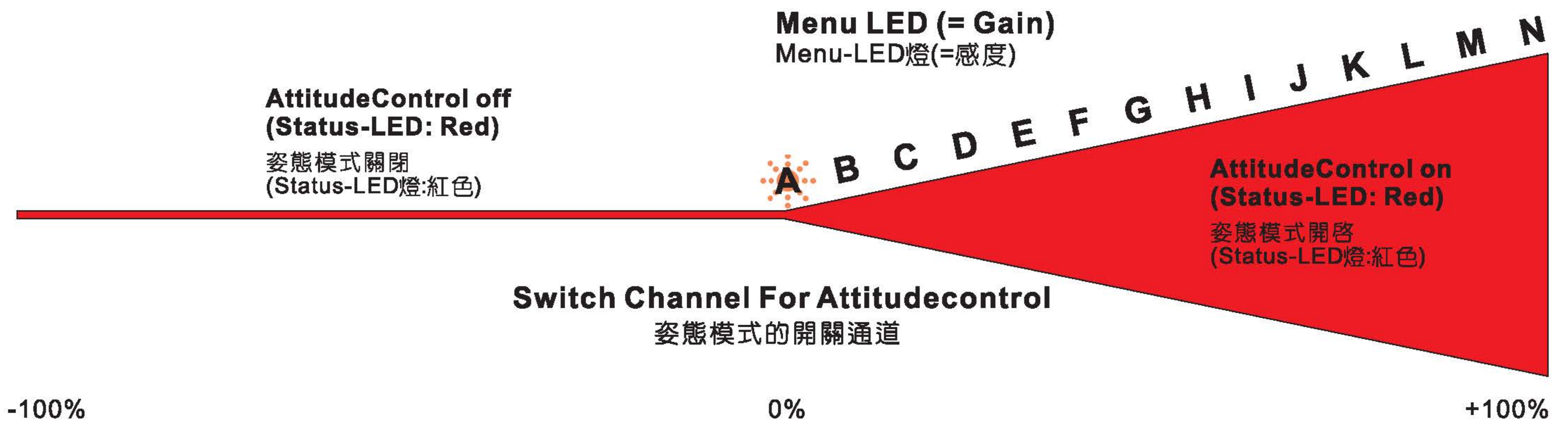

For the first flight it is recommended to adjust the throw of the AttitudeControl channel just until Menu LED G lights up when AttitudeControl is activated with the switch on the transmitter. Later onwards you may increase or decrease the throw which determines how fast and violent the helicopter will be rotated back to and held in horizontal position. If the switch channel is in "AttitudeControl off" position the amount of throw is not of importance for AttitudeControl.

首次飛行，建議您打開遙控器姿態模式通道的開關，調整姿態模式的通道輸出量，直到選單第 G 點 LED 燈亮起。之後，您可以增加或減少輸出量，來決定直昇機的飛行速度、暴力程度，以及回正時的水平位置。如果開關通道處於「姿態模式關閉」的位置，通道輸出量對姿態模式就不那麼重要了。

If switching AttitudeControl works the other way round (one of the Menu LEDs B - N lights up when the AttitudeControl switch is in "off"-Position and you can't increase further than Menu LED A when the switch is in "on"-Position) then reverse the channel for AttitudeControl by using the servo reverse function of your transmitter.

如果開啓姿態模式後，雖然可以動作但是方向相反(選單 LED燈 B- N 其中一個亮起，但是，姿態模式的開關是處於「關閉」位置，且移動開關到「開啓」位置時，您所增加的伺服輸出量無論如何都無法超越選單 LED 燈 A)，此時，請使用您遙控器的伺服反向功能來反向通道即可。

If using the tail gyro control channel also for AttitudeControl the amount of throw determines as usual the height of gyro gain when switched into direction "AttitudeControl off". Moving the channel by using a switch into the other direction the amount of tail gyro gain will be stored temporarily and AttitudeControl is activated. The amount of throw into this direction determines the height of AttitudeControl gain.

如果利用尾陀螺儀控制通道來控制姿態模式，其控制方式和控制尾陀螺儀是一樣的，伺服輸出量決定了陀螺儀以及姿態模式的感度。將尾陀螺儀搖桿往一個方向移動，系統會記憶這個方向的伺服輸出量，姿態模式會被開啓。這個方向的伺服輸出量決定了姿態模式的感度。



CAUTION
注意

When using AttitudeControl with combined switch channel make sure AttitudeControl is at least deactivated once before take off. Otherwise the tail gyro gain would be minimal as the system would not yet have been able to determine your tail gain setting after initialization.

當使用姿態模式-組合開關通道時，請確定姿態模式在起飛前至少關閉過一次。否則，系統會將尾陀螺儀感度限縮在最小值，因為在初始化後，系統無法判斷您所調整的尾陀螺儀感度。

CAUTION
注意

With this type of operation it is absolutely necessary to use a switch that changes the control directions directly and without intermediate steps. In particular, do not use a slider or delay function for switching the gain channel on the transmitter! Otherwise, when you activate AttitudeControl the tail gyro sensitivity would be decreased to 0% at first before the system turns on the AttitudeControl. You would have 0% of tail gyro gain when AttitudeControl is active as the system stores the last valid tail gyro value!

在此模式下，絕對要使用一個直接控制方向且沒有中間步驟的開關。特別是，不要使用遙控器滑套！否則，當你開啓姿態模式時，尾陀螺儀的靈敏度會下降到 0%。所以，當姿態模式開啓時，您的尾陀螺感度會是 0%，因為系統會自動存儲最後一個尾陀螺儀感度！

FUNCTIONAL TEST OF ATTITUDECONTROL

姿態模式功能測試

When activating AttitudeControl you should be able to see an immediate impact on the swashplate control: If the heli is tilted to one side, MICROBEAST PLUS permanently steers the swashplate opposed to the inclination. In the region around horizontal position the swashplate will always stay nearly horizontal to the ground. The system constantly tries to bring the helicopter back to the horizontal position as long as the helicopter is oblique.

當開啓姿態模式時，您應該可以看到十字盤控制的直接影響，如果直昇機向一側傾斜，MICROBEAST PLUS 將永遠控制十字盤並補償相反傾角使直昇機回到水平位置。

Tilt the helicopter forwards, backwards or to the side
直昇機向前、向後或向側邊傾斜

The system will try to level the helicopter by keeping the swashplate horizontal or moving it against rotation as long as the **helicopter is tilted.**

系統將不斷補償，修正直昇機傾斜來維持十字盤水平位置。

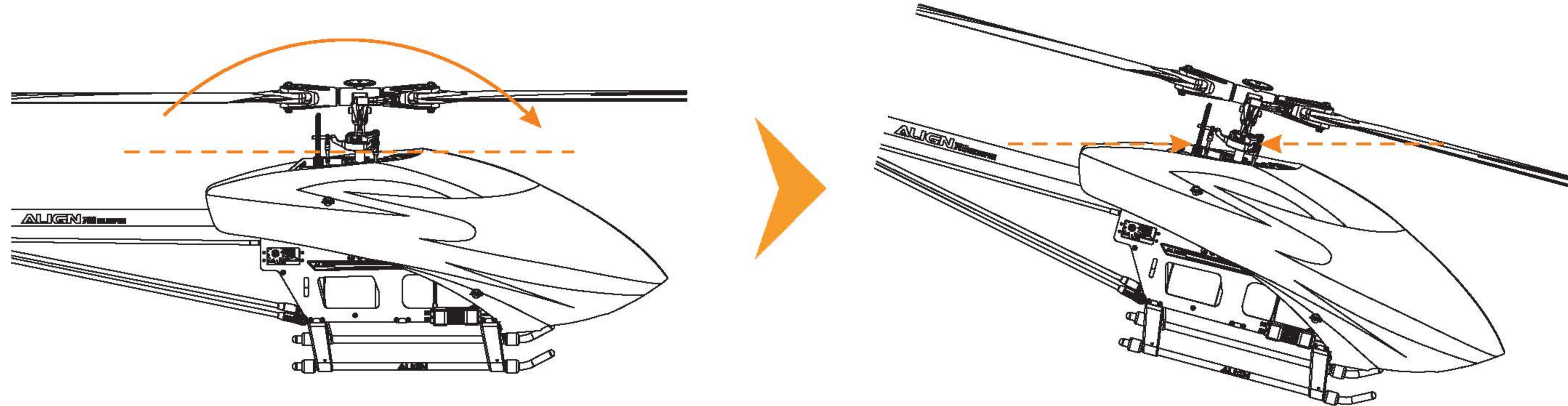

If on the other hand AttitudeControl is deactivated the system will only counteract sudden movements but will not control the swashplate as long the heli is not moved even in tilted position. 另一方面，若「關閉」姿態模式，系統只會抵銷突然的動作，但不會控制十字盤，雖然直昇機仍然處於傾斜狀態。

MENU OVERVIEW

選單總覽

ALIGN

Setup Menu(Menu LED Solid) 設定選單(Menu-LED 恆亮)

		Off 熄滅	Flashing Purple 紫燈閃爍	Purple 紫燈	Flashing Red 紅燈閃爍	Red 紅燈	Flashing Blue 藍燈閃爍	Blue 藍燈	Red / Blue 紅色/藍色
A	Device Orientation 陀螺固定方向	Horizontal Socket in Front 水平插座在前面	Vertical Socket in Front 垂直插座在前面	Hor. Inv. Socket in Front 水平-逆.插座在前面	Vert. Inv. Socket in Front 垂直-逆.插座在前面	Horizontal Socket at Back 水平插座在後面	Vertical Socket at Back 垂直插座在後面	Hor. Inv. Socket at Back 水平-逆.插座在後面	Vert. Inv. Socket at Back 垂直-逆.插座在後面
B	Swashplate Servo Update Rate 十字盤舵機升級率	User Defined 使用者自定義	—	50 Hz*	65 Hz	120 Hz	165 Hz	200 Hz	—
C	Rudder Servo Center Pulse 尾舵機中立點脈衝頻率	User Defined 使用者自定義	—	960 μs	—	760 μs	—	1520 μs	—
D	Rudder Servo Update Rate 尾舵機中立點升級率	User Defined 使用者自定義	—	50 Hz*	165 Hz	270 Hz	333 Hz	(560 Hz)	—
E	Rudder Servo Limit 尾舵機極限	Use Rudder Stick To Move Servo To Right Endpoint And Wait, Then Left Endpoint And Wait (or Vice Versa) 尾舵搖桿移到右極限並等待/再移到左極限並等待							
F	Tail Gyro Direction 尾陀螺方向	—	—	—	—	Normal* 正常*	—	Inverted 反向	—
G	Swashplate Servo Trim 十字盤舵機微調	Reference Position 原始位置	—	Servo CH1 CH1伺服器	—	Servo CH2 CH2伺服器	—	Servo CH3 CH3伺服器	—
H	Swashplate Mixing Type 十字盤混控	User Defined 使用者自定義	—	Mechanical 機械混控	90°	120° *	140° *	135° / 140° (1=1)	—
I	Swashplate Servo Directions 十字盤舵機方向	Nor Inv Inv 正/逆/逆	—	Nor Nor Inv* 正/正/逆*	—	Nor Inv Nor 正/逆/正	—	Nor Nor Nor 正/正/正	—
J	Swashplate Servo Throw 十字盤舵機行程	Use aileron stick to adjust 6° cyclic pitch on the roll axis to one direction (blades aligned with fuselage). 用副翼搖桿調整到6° (主旋翼與機身綁定)							
K	Collective Pitch 集體螺距	Set collective stick to max/min position and use aileron stick to adjust desired pitch. Set pitch direction by rudder stick input: status-led blue = positive pitch, red = negative pitch. 將螺距搖桿推到最高點和最低點的同時用副翼搖桿來做選擇。 移動尾舵搖桿設定螺距方向: Status-LED 藍色 = 正螺距, 紅色 = 負螺距。							
L	Swashplate Servo Limit 十字盤舵機極限	Move aileron, elevator and thrust stick-adjust maximum limit with rudder stick 移動副翼、升降和螺距搖桿, 在最大極限位置用尾舵搖桿做選擇							
M	Swashplate Gyro Directions 十字盤陀螺方向	inv inv 逆/逆	—	Inv Nor 逆/正	—	Nor inv 正/逆	—	Nor Nor* 正/正*	—
N	Internal Rpm Governor 內部RPM定速器	Governor Off* 定速模式關閉	—	—	—	Electric Heli 電動直昇機	—	Nitro/Gas Heli 引擎直昇機	—

* Factory Setting * 出廠預設值

Governor Setup Menu(Menu LED Flashing Slowly) 定速模式選單(Menu-LED燈緩慢閃爍)

		Off 熄滅	Flashing Purple 紫燈閃爍	Purple 紫燈	Flashing Red 紅燈閃爍	Red 紅燈	Flashing Blue 藍燈閃爍	Blue 藍燈	Red / Blue 紅色/藍色
A	Test Mode 測試模式	"Nitro/gas Heli": Status-led Blue When Magnet Passes Sensor "Electric Heli": Status-led Red When Motor Is Running "引擎直昇機"模式: 磁鐵經過感應器 Status-LED燈亮藍燈 "電動直昇機"模式: 馬達啟動時Status-LED亮紅燈							
B	Motor Off/Idle Position 馬達關閉/Idle位置	"Nitro/gas Heli": Throttle Servo To (increased) Idle Position "Electric Heli": Throttle In"motor Off" Position, Just Before Motor Starts "Nitro" 模式: 磁鐵經過藍光感應器 Status-LED燈亮藍燈"Electric" 模式: 馬達啟動時Status-LED亮紅燈							
C	Full Throttle Position 最大油門位置	Set throttle channel/throttle servo to full throttle position. 油門通道/油門伺服器設定在全油門位置							
D	Transmitter Setup 遙控器設定	RPM Governor off 定速模式關閉	—	RPM Governor maximum 定速模式最大值	—	RPM Governor on 定速模式開啓	—	RPM Governor autorotation 定速模式熄火(降落)	—
E	Signal Divider 轉速訊號分配表	1	2	3	4*	5	6	7	—
F	Main Gear Ratio (sum Out Of F + G + H If Not "user Defined" At Menu Point F)	User Defined 使用者自定義	8	9*	10	11	12	13	14
G	主馬達-齒輪比 (F + G + H總和, 如果不是則為第F點的 "使用者自訂義")	+0.00	+0.20	+0.40*	+0.60	+0.80	—	—	—
H		+0.00	+0.05	+0.10*	+0.15	—	—	—	—

* Factory Setting * 出廠預設值

Paramete Menu(Menu-LED is Flashing Quickly)

參數功能表(Menu-LED 快速閃爍)

		Off 熄滅	Flashing Purple 紫燈閃爍	Purple 紫燈	Flashing Red 紅燈閃爍	Red 紅燈	Flashing Blue 藍燈閃爍	Blue 藍燈
A	Swashplate Quick Trim / Attitude Control Trim 十字盤快速微調/姿態模式微調	Use aileron and elevator stick to trim, hold button 2s to trim rudder. Reset all by rudder stick input. Switch trim mode by activating AttitudeControl using the AttitudeControl switch channel. 移動副翼和升降，用尾舵搖桿還原初始化設定：使用姿態模式開關啟動姿態模式開關微調模式。						
B	Control Style 控制風格	User Defined 使用者自定義	————	Normal 普通	Sport* 運動*	Pro 專業	Extreme 極限	TX Mode 遙控器
C	Speed Flight Stability 高速飛行穩定性	User Defined 使用者自定義	————	Very Low 極低	Low 低	Medium* 普通*	High 高	Very High 極高
D	Rudder Rate Consistency 尾舵速率一致性	User Defined 使用者自定義	————	Very Low 極低	Low 低	Medium* 普通*	High 高	Very High 極高
E	Stick Deadzone 搖桿死區	User Defined 使用者自定義	————	Very Small 極小	Small* 小*	Medium 普通	Large 大	Very Large 極大
F	Torque Precompensation 反扭力補償	User Defined 使用者自定義	————	Off 關閉	Low - Nor 低-正	High - Nor 高-正	Low - Inv 低-逆	High - Inv 高-逆
G	Cyclic Response 循環反應	User Defined 使用者自定義	————	Normal* 普通	Slightly Increased 增加一點	Increased 增加	Aggressive 激進	Very Aggressive 極激進
H	Pitch Boost 螺距-增強	User Defined 使用者自定義	————	Off* 關閉*	Low 低	Medium 普通*	High 高	Very High 極高
I	Throttle Response 油門反應	User Defined 使用者自定義	————	Normal* 普通	Slightly Increased 增加一點	Increased 增加	Aggressive 激進	Very Aggressive 極激進
J	Slow Ramp Up Speed 緩起動速率	User Defined 使用者自定義	————	50 rps	100 rps	200 rps*	300 rps	400 rps
K	Fast Ramp Up Speed 快速啟動速率	User Defined 使用者自定義	————	Using Slow Rampup Speed 使用緩起動速率	300 rps	500 rps*	700 rps	900 rps
L	Attitudecontrol Mode 姿態模式	Attitude Control Operation mode 姿態操作模式	Attitude Control Disabled* 姿態模式失效*	Bail out rescue 救援	Bail Out Rescue W. Pitch Control 救援-螺距	3D - Mode 3D模式	3D Mode w. Pitch Control 3D模式-螺距	Flight Trainer 飛行訓練
M	(Attitudecontrol Pitch) (姿態模式螺距)	Adjust by giving aileron stick input. Reset with rudder stick input. 移動副翼搖桿執行調整、移動尾舵遙桿執行重設。						

* Factory Setting * 出廠預設值

RECEIVER SETUP MENU(Menu-LED is flashing quickly)

接收器設定選單(Menu-LED 燈快閃)

		Off 熄滅	Flashing Purple 紫燈閃爍	Purple 紫燈	Flashing Red 紅燈閃爍	Red 紅燈	Flashing Blue 藍燈閃爍	Blue 藍燈
A	Receiver Type 接收器類型	Standard* 傳統型*	JR RJ01 Remote Satellite JR RJ01 衛星天線	Spektrum Satellite Spektrum 衛星天線	Futaba S-BUS	SRXL	SPPM	————
B	Collective Pitch 集體螺距	<ul style="list-style-type: none"> • Status-LED light up in blue color if valid incoming signal from receiver. • Move the stick/channel on the transmitter you want to assign. The Status-LED will flash briefly in case the movement has been detected. • Menu points H, I and J can be skipped in case you don't want to use the specific function or you want to use nitro RPM Governor and/or AttitudeControl without separate channel. • To load the default channel assingment keep the button pressed at any menu point. You will directly jump to menu point N. • 成功收到接收器信號時 Status-LED 燈會亮藍燈。 • 移動遙控器搖桿分配通道功能。當指令被偵測到時 Status-LED 燈會快閃。 • 如果你不想使用特定功能或是不想使用分開通道的 RPM定速模式/或姿態模式時可以略過選單第 H、I、J 點。 • 如果要加載各頻道的原廠設定值時，在每個選單皆長按按鍵，就會直接跳到選單第 N 點。 						
C	Aileron 副翼							
D	Elevator 升降舵							
E	Rudder 尾舵							
F	Tail Gyro Gain 感度							
G	Throttle [CH5] 油門 [CH5]							
H	Auxiliary [CH6] (Optional) 輔助通道 (CH6)							
I	RPM Governor (Optional) 定速模式							
J	AttitudeControl (Optional) 姿態模式							
N	Throttle Failsafe Position 失控保護位置 -油門	Move throttle to failsafe position and push button to save all menu items and exit menu. 移動油門到失控保護位置並按下按鈕儲存後離開選單。						

* Factory Setting * 出廠預設值

www.align.com
www.
www.align.com
www.alig
www.align
www.align.com.tw
www.align.com.

ALIGN